



PARTS CATALOGUE

TDM850 (4TX8) EUROPE

TDM850N (4TX9) OCEANIA



A3

FOREWORD

This Parts Catalogue is related to the parts for the model(s) in the below frame. When you are ordering replacement parts, please refer to this Parts Catalogue and quote both part numbers and part names correctly.

TDM850(4TX8)/TDM850N(4TX9)

1. Modifications or additions which have been made after issue of the Parts Catalogue will be announced in the Yamaha Parts News. It is advisable that you make necessary corrections to the Parts Catalogue according to the Yamaha Parts News.

2. Abbreviations
The Following abbreviations are used in this Parts Catalogue.

- "UR" Use specified parts number.
- "UN" Use as many as needed.
- "AP" Alternate Parts
- "LM" Local Made (Parts need to be ordered locally)
- "F#" Frame No. (Applicable machine No.)

3. Parts, which are to be supplied in an assembly, are listed with a dot(.) in front of the part name as shown below.

EXAMPLE

- CARBURETOR ASSY
- .JET, PILOT
- .NOZZLE, MAIN

4. Number of component for assembly
The numeral appearing to the right of each component part indicates the quantity of parts for each assembly unit.

EXAMPLE

PART NO.	DESCRIPTION	Q'TY	REMARKS
2F5-83310-60	FRONT FLASHER LIGHT ASSY	2	
115-83311-60	.BULB (6V-18W)	1	
1M1-83309-60	.REFLECTOR	1	

5. Applicable colors of graphics are represented in the "REMARKS" as shown below.

PART NO.	DESCRIPTION	Q'TY	REMARKS
2N4-24110-00-X5	.FUEL TANK COMP.	2	MXR
3J1-24240-10	.GRAPHIC, FUEL TANK	1	for MXR

6. Applicable Serial No.

Engine Serial No.

Frame Serial No.

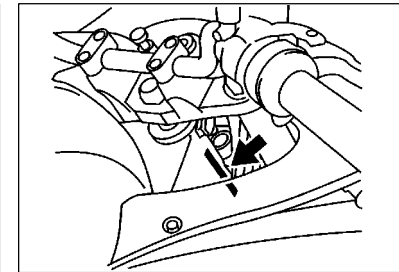
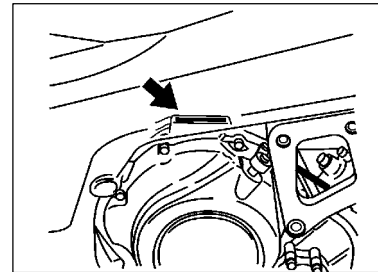

7. Note that the illustrations for reference in finding parts numbers, not to be used for assembling. When assembling, please use the applicable service manual.
8. The asterisk (*) before a reference number indicates modification items after the first edition.

MODEL LABEL

(1) A label called "Model Label" is affixed in the location as indicated in (3) below.
When using this parts catalogue, please be sure to cross-refer the "model code – production code No." in the catalogue to the "model code – production code No." indicated on the Model Label affixed onto the product concerned.

(2) "Model Label" Indication

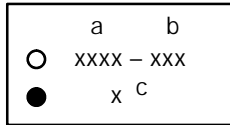

a: Model Type Code
b: Production Code No.
c: Colouring Type

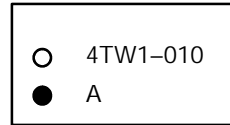

(3) Model Label Affixing Location

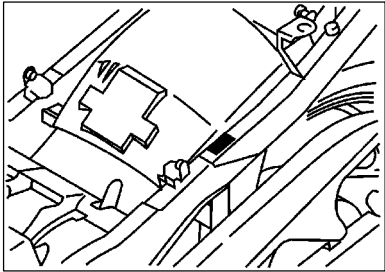

(4) Model Code – Production Code Number of Model Listed in This Parts Catalog

Model Code	Production Code No.	Country (destination)	Model Code	Production Code No.	Country (destination)
4TX8	020	BELGIUM			
	040	DENMARK			
	060	FINLAND			
	070	ENGLAND			
	080	GREECE			
	090	ITALY			
	091				
	100	HOLLAND			
	101				
	110	NORWAY			
	120	PORTUGAL			
	130	SWEDEN			
4TX9	010	AUSTRALIA			

(5) Colouring Information

Model Code	Colouring type code	Colour code	Colour Name	Abbreviation
4TX8	A	004B	BLACK 2	BL2
4TX8 4TX9	B	0775	BLUE METALLIC C	BMC
4TX8 4TX9	C	0567	DARK PURPLISH RED COCKTAIL 3	DPRC3

FIG. 1 CYLINDER HEAD

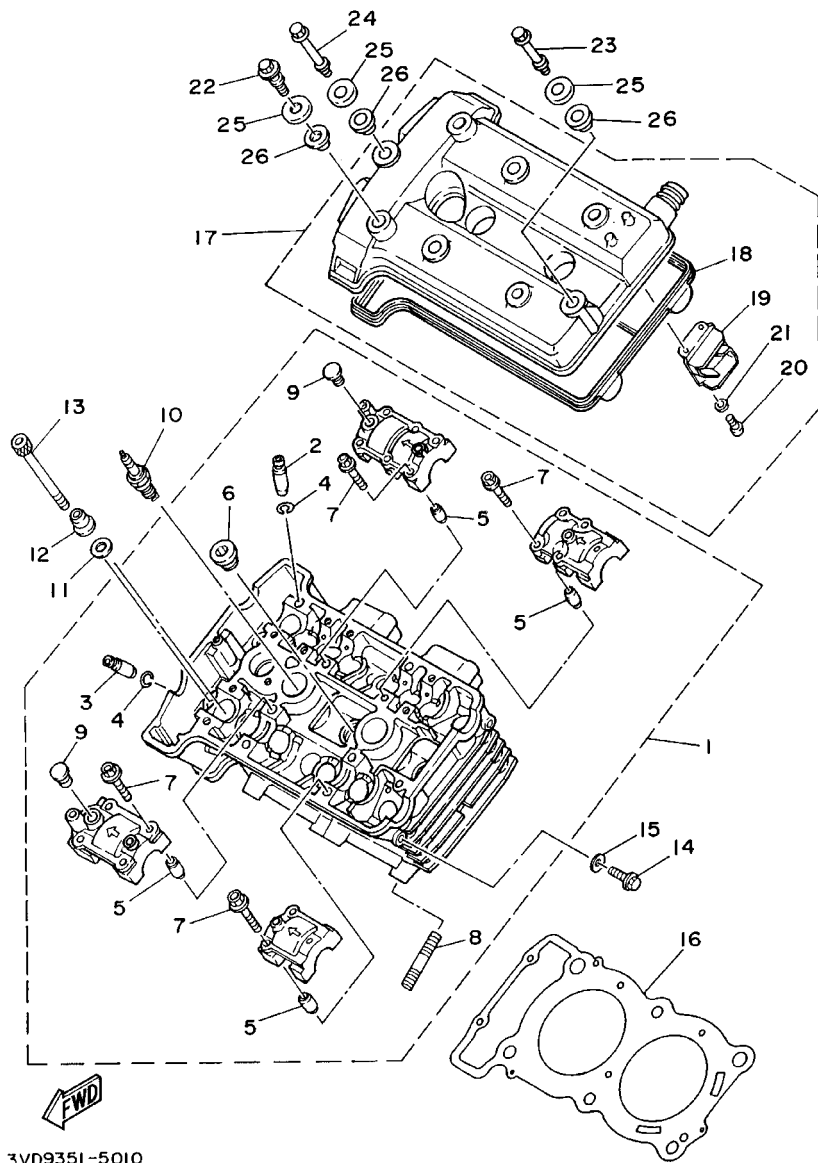

3VD935I-5010

REF. NO.	PART NO.	DESCRIPTION	4TX8	4TX9			REMARKS
1	3VD-11101-20	CYLINDER HEAD ASSY	1	1			
2	3LD-11133-10	.GUIDE, INTAKE VALVE	6	6			
3	3LD-11134-10	.GUIDE, EXHAUST VALVE	4	4			
4	93440-10109	.CIRCLIP	10	10			
5	99510-08016	.PIN, DOWEL	8	8			
6	90340-18101	.PLUG, STRAIGHT SCREW	2	2			
7	90105-06153	.BOLT, WASHER BASED	16	16			
8	90116-08548	.BOLT, STUD	4	4			
9	90338-10150	.PLUG	2	2			
10	94701-00241	PLUG, SPARK (NGK DPR8EA-9)	2	2			UR
	94701-00242	PLUG, SPARK (ND X24EPR-U9)	2	2			UR
11	90201-103M4	WASHER, PLATE	6	6			
12	90179-10414	NUT	6	6			
13	91317-06150	BOLT	2	2			
14	95024-08012	BOLT, FLANGE	1	1			
15	90430-08119	GASKET	1	1			
16	4NX-11181-00	GASKET, CYLINDER HEAD 1	1	1			
17	4NX-Y1119-10	COVER ASSY, CYLINDER HEAD	1	1			
18	3LD-11193-01	.GASKET, HEAD COVER 1	1	1			
19	3LD-11160-02	.BREATHER ASSY	1	1			
20	98507-04006	.SCREW, PAN HEAD	2	2			
21	92907-04600	.WASHER	2	2			
22	90109-064F0	BOLT	6	6			
23	90109-062G1	BOLT	1	1			
24	90109-062G2	BOLT	1	1			
25	90209-11262	.WASHER	8	8			
26	2GH-1111G-00	RUBBER, MOUNT 1	8	8			

FIG. 2 CYLINDER

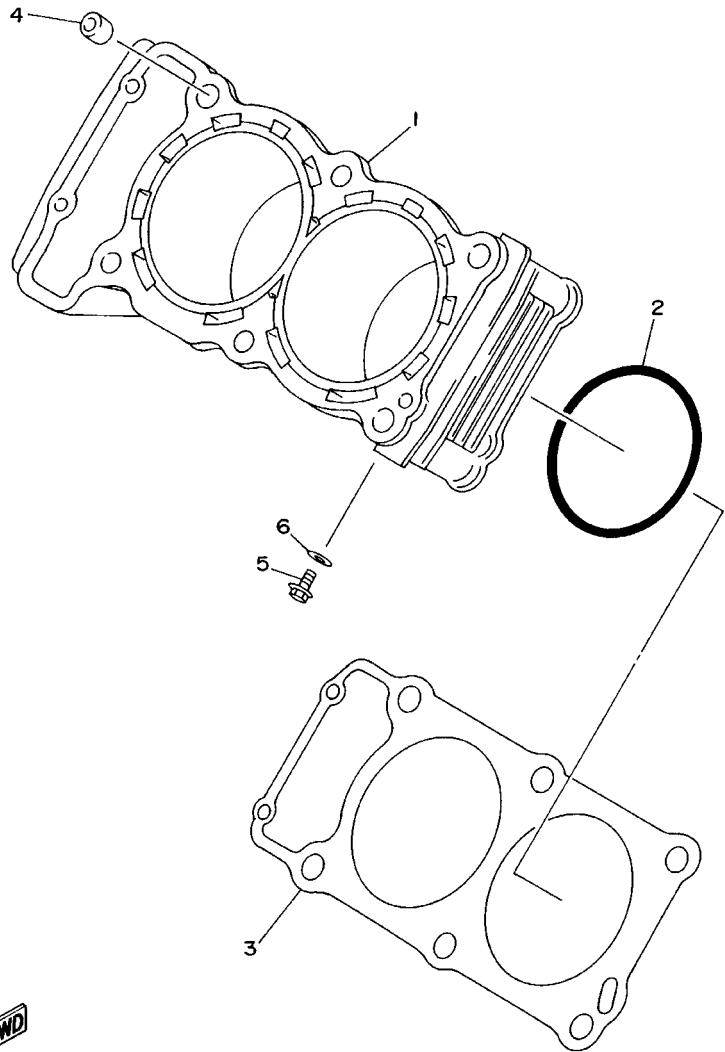

REF. NO.	PART NO.	DESCRIPTION	4TX8	4TX9				REMARKS
1	4UN-11310-00	CYLINDER	1	1				
2	93210-90785	O-RING	2	2				
3	3VD-11351-00	GASKET, CYLINDER	1	1				
4	99530-14016	PIN, DOWEL	2	2				
5	90153-06029	SCREW, HEXAGON	1	1				
6	90430-06014	GASKET	1	1				

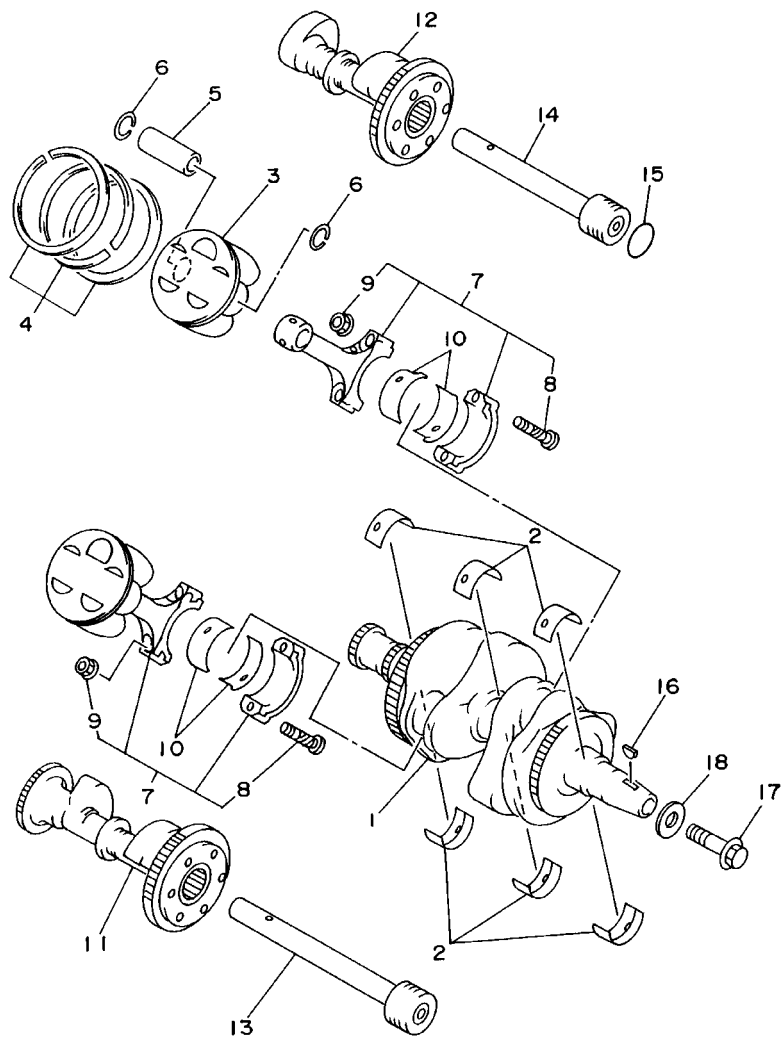

4NX1010-5020

FIG. 3 CRANKSHAFT. PISTON

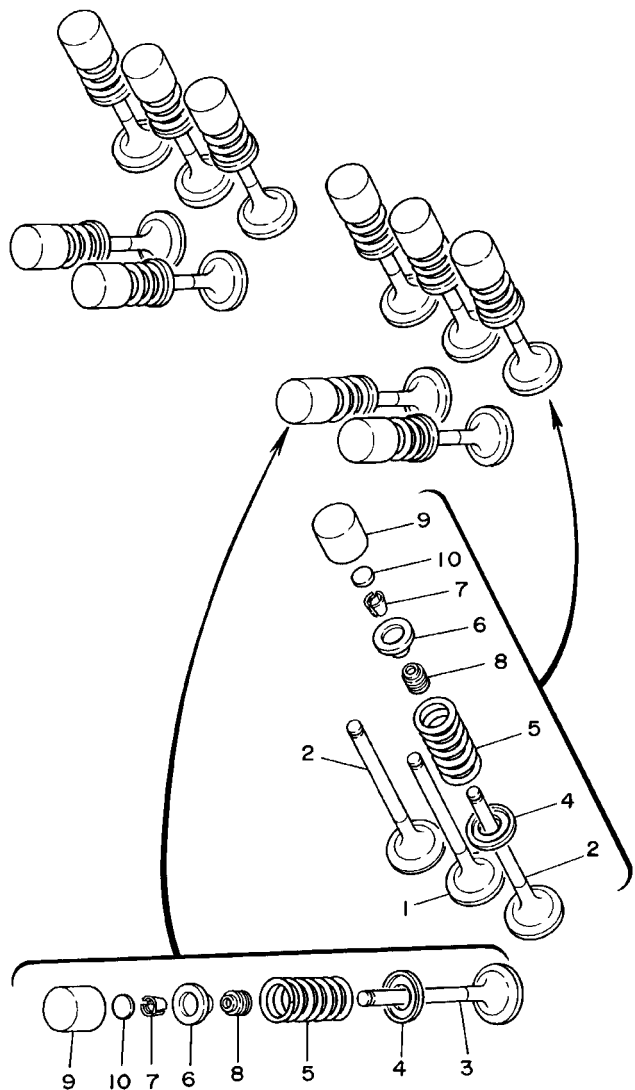

4NX1010-5030

REF. NO.	PART NO.	DESCRIPTION	4TX8	4TX9	REMARKS
1	4NX-11400-00	CRANKSHAFT ASSY	1	1	
2	3LD-11416-00	PLANE BEARING, CRANKSHAFT 1	6	6	UR BLUE
	3LD-11416-10	PLANE BEARING, CRANKSHAFT 1	6	6	UR BLACK
	3LD-11416-20	PLANE BEARING, CRANKSHAFT 1	6	6	UR BROWN
	3LD-11416-30	PLANE BEARING, CRANKSHAFT 1	6	6	UR GREEN
	3LD-11416-40	PLANE BEARING, CRANKSHAFT 1	6	6	UR YELLOW
	3LD-11416-50	PLANE BEARING, CRANKSHAFT 1	6	6	UR PINK
	3LD-11416-60	PLANE BEARING, CRANKSHAFT 1	6	6	UR RED
3	4NX-11631-00	PISTON (STD)	2	2	
	4NX-11636-00	PISTON (0.50MM O/S)	2	2	AP
	4NX-11638-00	PISTON (1.00MM O/S)	2	2	AP
4	3VD-11610-00	PISTON RING SET (STD)	2	2	
	3VD-11610-20	PISTON RING SET (0.50MM O/S)	2	2	AP
	3VD-11610-40	PISTON RING SET (1.00MM O/S)	2	2	AP
5	3LD-11633-00	PIN, PISTON	2	2	
6	93450-22027	CIRCLIP	4	4	
7	3VD-11650-00	CONNECTING ROD ASSY	2	2	
8	3LD-11654-00	.BOLT, CONNECTING ROD	2	2	
9	90179-09379	.NUT	2	2	
10	3LD-11656-00	PLANE BEARING, CONNECTING ROD	4	4	UR BLUE
	3LD-11656-10	PLANE BEARING, CONNECTING ROD	4	4	UR BLACK
	3LD-11656-20	PLANE BEARING, CONNECTING ROD	4	4	UR BROWN
	3LD-11656-30	PLANE BEARING, CONNECTING ROD	4	4	UR GREEN
11	4NX-11500-00	BALANCER ASSY	1	1	
12	4NX-11510-00	BALANCER ASSY, 2	1	1	
13	3LD-11583-00	SHAFT, BALANCER 1	1	1	
14	3LD-11584-00	SHAFT, BALANCER 2	1	1	



3LD1351-9040

FIG. 4 VALVE

REF. NO.	PART NO.	DESCRIPTION	4TX8	4TX9			REMARKS
1	3LD-12111-01	VALVE, INTAKE (3LD.)	2	2			
2	3LD-12112-01	VALVE, INTAKE 2 (3LD.)	4	4			
3	3LD-12121-00	VALVE, EXHAUST (3LD)	4	4			
4	1WG-12116-00	SEAT, VALVE SPRING	10	10			
5	3LD-12113-00	SPRING, VALVE INNER	10	10			BLUE
6	3LD-12117-00	RETAINER, VALVE SPRING	10	10			
7	3LD-12118-00	COTTER, VALVE	20	20			
8	51Y-12119-00	SEAL, VALVE STEM	10	10			
9	1WG-12153-21	LIFTER, VALVE	10	10			UR BLUE
	1WG-12153-31	LIFTER, VALVE	10	10			UR RED
10	3LD-12168-00	PAD, ADJUSTING (1.20)	10	10			UR
	3LD-12168-20	PAD, ADJUSTING (1.25)	10	10			UR
	3LD-12168-40	PAD, ADJUSTING (1.30)	10	10			UR
	3LD-12168-60	PAD, ADJUSTING (1.35)	10	10			UR
	3LD-12168-80	PAD, ADJUSTING (1.40)	10	10			UR
	3LD-12168-A0	PAD, ADJUSTING (1.45)	10	10			UR
	3LD-12168-F0	PAD, ADJUSTING (1.50)	10	10			UR
	3LD-12168-H1	PAD, ADJUSTING (1.55)	10	10			UR
	3LD-12168-K1	PAD, ADJUSTING (1.60)	10	10			UR
	3LD-12168-M1	PAD, ADJUSTING (1.65)	10	10			UR
	3LD-12168-R1	PAD, ADJUSTING (1.70)	10	10			UR
	3LD-12168-U1	PAD, ADJUSTING (1.75)	10	10			UR
	3LD-12168-W1	PAD, ADJUSTING (1.80)	10	10			UR
	3LD-12168-Y1	PAD, ADJUSTING (1.85)	10	10			UR
	3LD-12169-11	PAD, ADJUSTING (1.90)	10	10			UR
	3LD-12169-31	PAD, ADJUSTING (1.95)	10	10			UR
	3LD-12169-50	PAD, ADJUSTING (2.00)	10	10			UR

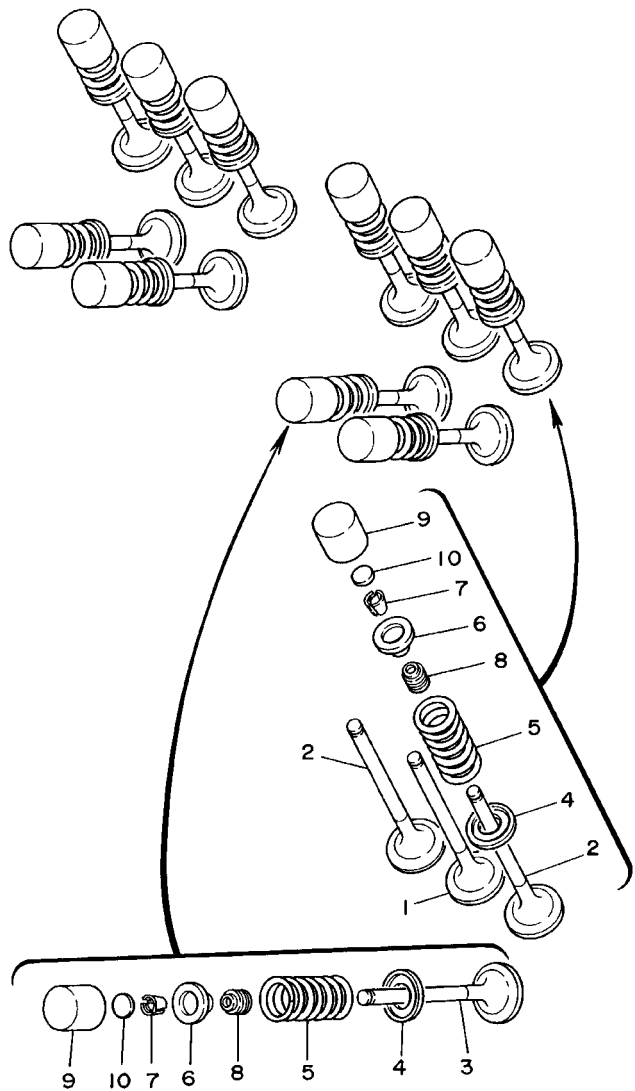

3LD1351-9040

FIG. 4 VALVE

REF. NO.	PART NO.	DESCRIPTION	4TX8	4TX9	REMARKS
10	3LD-12169-70	PAD, ADJUSTING (2.05)	10	10	UR
	3LD-12169-90	PAD, ADJUSTING (2.10)	10	10	UR
	3LD-12169-E0	PAD, ADJUSTING (2.15)	10	10	UR
	3LD-12169-G0	PAD, ADJUSTING (2.20)	10	10	UR
	3LD-12169-J0	PAD, ADJUSTING (2.25)	10	10	UR
	3LD-12169-L0	PAD, ADJUSTING (2.30)	10	10	UR
	3LD-12169-N0	PAD, ADJUSTING (2.35)	10	10	UR
	3LD-12169-T0	PAD, ADJUSTING (2.40)	10	10	UR

FIG. 5 CAMSHAFT. CHAIN

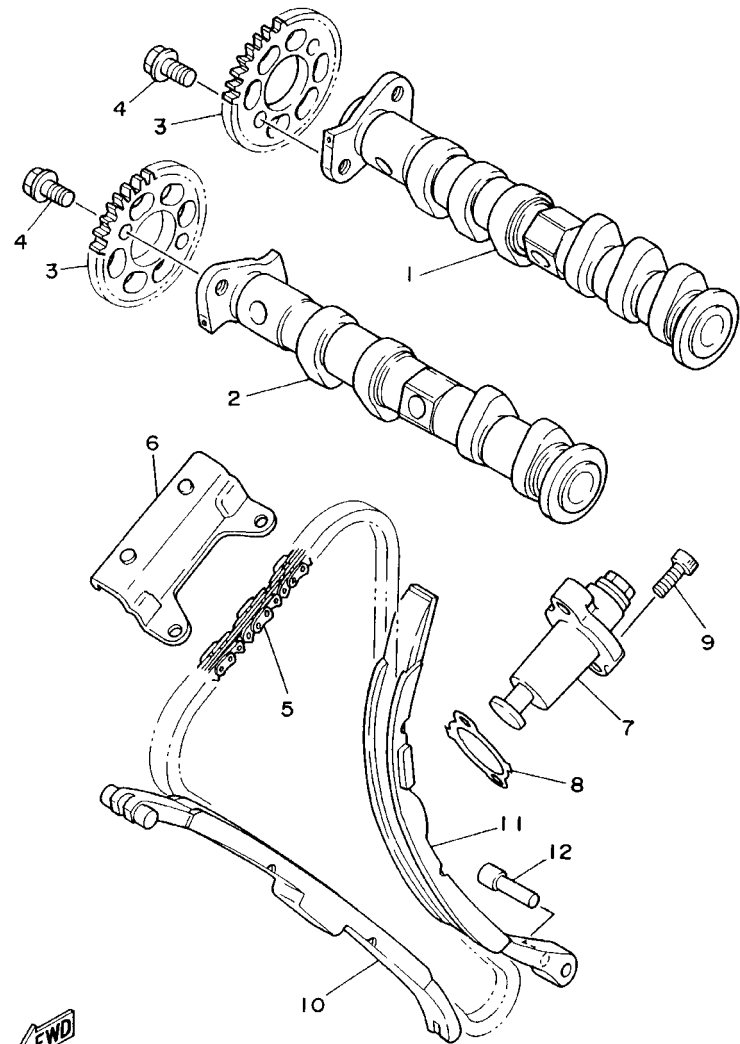

3VD935I-5050

REF. NO.	PART NO.	DESCRIPTION	4TX8	4TX9				REMARKS
1	4NX-12171-00	CAMSHAFT 1	1	1				
2	4NX-12181-00	CAMSHAFT 2	1	1				
3	3LD-12176-00	SPROCKET, CAM CHAIN	2	2				
4	90105-07342	BOLT, WASHER BASED	4	4				
5	94591-40138	CHAIN (82RH2015-138L)	1	1				
6	3LD-12241-00	GUIDE, STOPPER 2	1	1				
7	3LD-12210-00	TENSIONER ASSY, CAM CHAIN	1	1				
8	3VD-12213-00	GASKET, TENSIONER CASE	1	1				
9	91314-06025	BOLT	2	2				
10	3LD-12251-00	DAMPER, CHAIN 1	1	1				
11	3LD-12252-00	DAMPER, CHAIN 2	1	1				
12	3LD-12247-00	SHAFT, TENSIONER	1	1				

FIG. 6 WATER PUMP

REF. NO.	PART NO.	DESCRIPTION	4TX8	4TX9				REMARKS
1	4UN-Y1242-00	WATER PUMP ASSY	1	1				
2	3LD-12439-00	.O-RING	1	1				
3	95024-06020	.BOLT, FLANGE	2	2				
4	99009-12400	.CIRCLIP	1	1				
5	95024-06012	.BOLT, FLANGE	1	1				
6	90430-06014	.GASKET	1	1				
7	93210-33133	.O-RING	1	1				
8	3VD-12459-00	GEAR, IMPELLER SHAFT	1	1				
9	90201-127E1	WASHER, PLATE	1	1				
10	95024-06030	BOLT, FLANGE	1	1				
11	95024-06045	BOLT, FLANGE	1	1				
12	95024-06060	BOLT, FLANGE	1	1				
13	3LD-12481-00	PIPE 1	1	1				
14	93210-21190	O-RING	2	2				
15	93210-357A2	O-RING	1	1				
16	4UN-12469-00	JOINT 1	1	1				
17	95027-06016	BOLT, FLANGE	2	2				

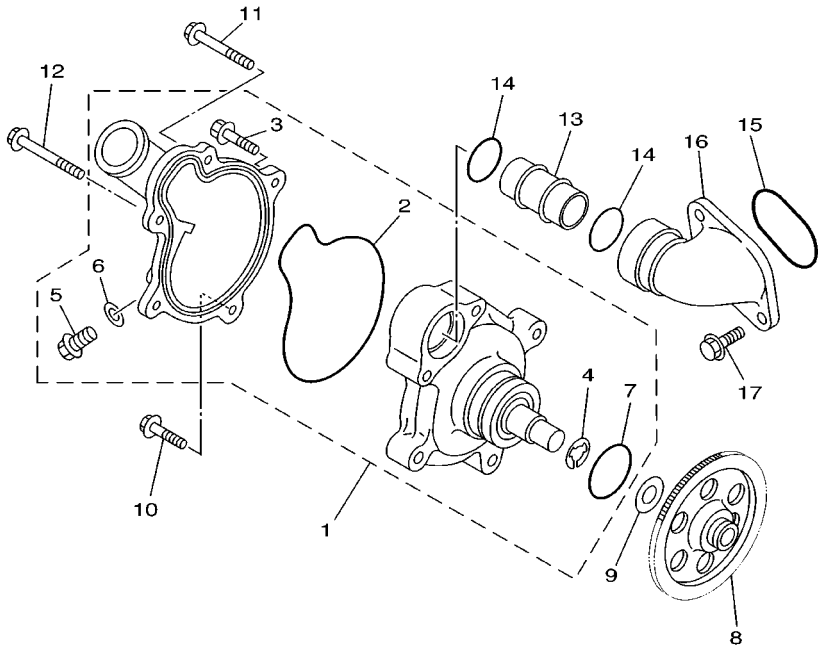

4TX1351-6060

FIG. 7 RADIATOR. HOSE

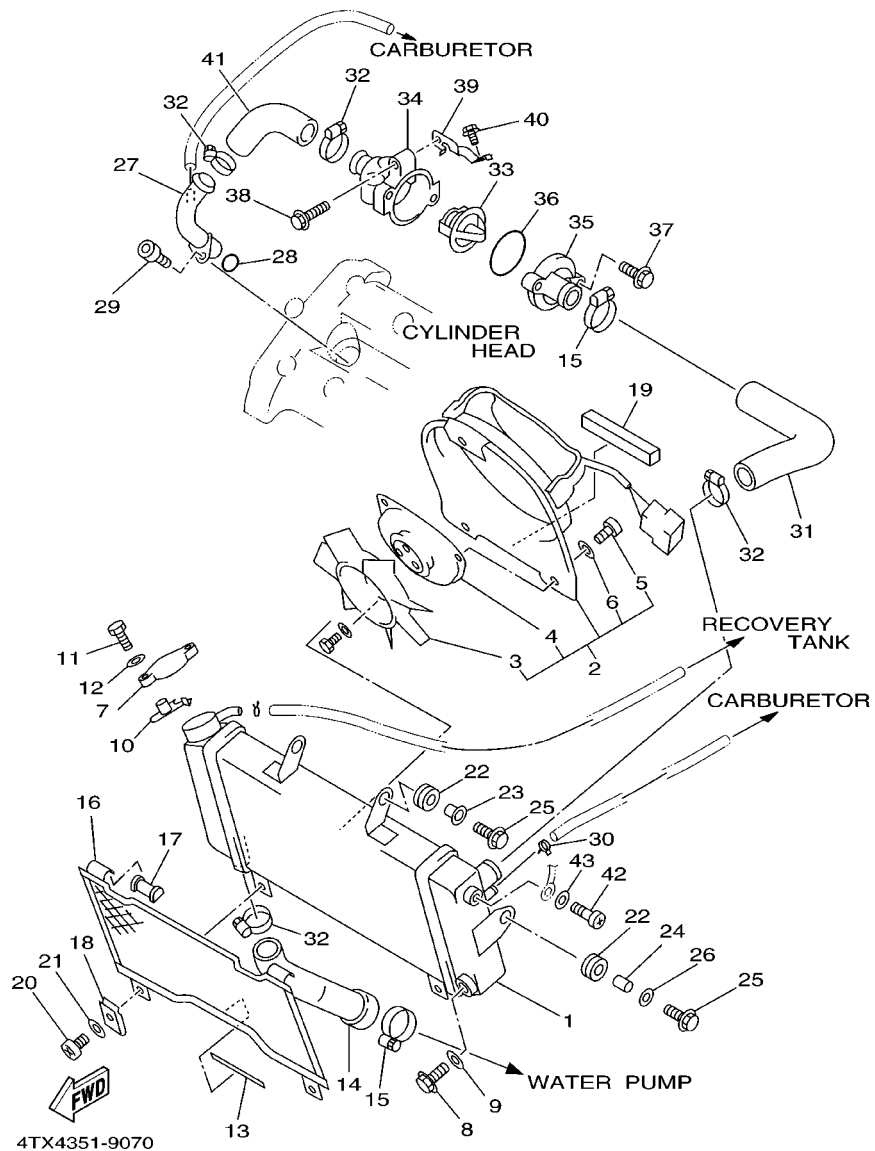

REF. NO.	PART NO.	DESCRIPTION	4TX8	4TX9	REMARKS
1	4TX-12461-40	RADIATOR ASSY	1	1	
2	4TX-12405-00	BLOWER ASSY	1	1	
3	1UF-12611-00	.FAN	1	1	
4	26H-12630-00	.MOTOR ASSY	1	1	
5	98507-05008	.SCREW, PAN HEAD	3	3	
6	92990-05600	.WASHER, PLATE	3	3	
7	4FL-12462-00	CAP, RADIATOR	1	1	
8	1AA-12561-00	PLUG, DRAIN COCK	1	1	
9	1AA-12435-00	GASKET	1	1	
10	1KT-12437-00	STOPPER	1	1	
11	97007-05012	BOLT	1	1	
12	92907-05600	WASHER, PLATE	1	1	
13	3VD-12465-00	DAMPER, RADIATOR	1	1	
14	4TX-12578-00	HOSE 3	1	1	
15	90450-38040	HOSE CLAMP ASSY	2	2	
16	1UF-12467-00	COVER, RADIATOR	1	1	
17	1UF-12435-00	GASKET	2	2	
18	90183-05024	NUT, SPRING	2	2	
19	4TX-12465-00	DAMPER, RADIATOR	1	1	
20	98507-05010	SCREW, PAN HEAD	2	2	
21	92907-05600	WASHER, PLATE	2	2	
22	90480-15363	GROMMET	4	4	
23	90387-0614M	COLLAR	2	2	
24	90387-0714B	COLLAR	2	2	
25	95807-06025	BOLT, FLANGE	4	4	
26	90201-06071	WASHER, PLATE	2	2	
27	4NX-12482-00	PIPE 2	1	1	

FIG. 7 RADIATOR. HOSE

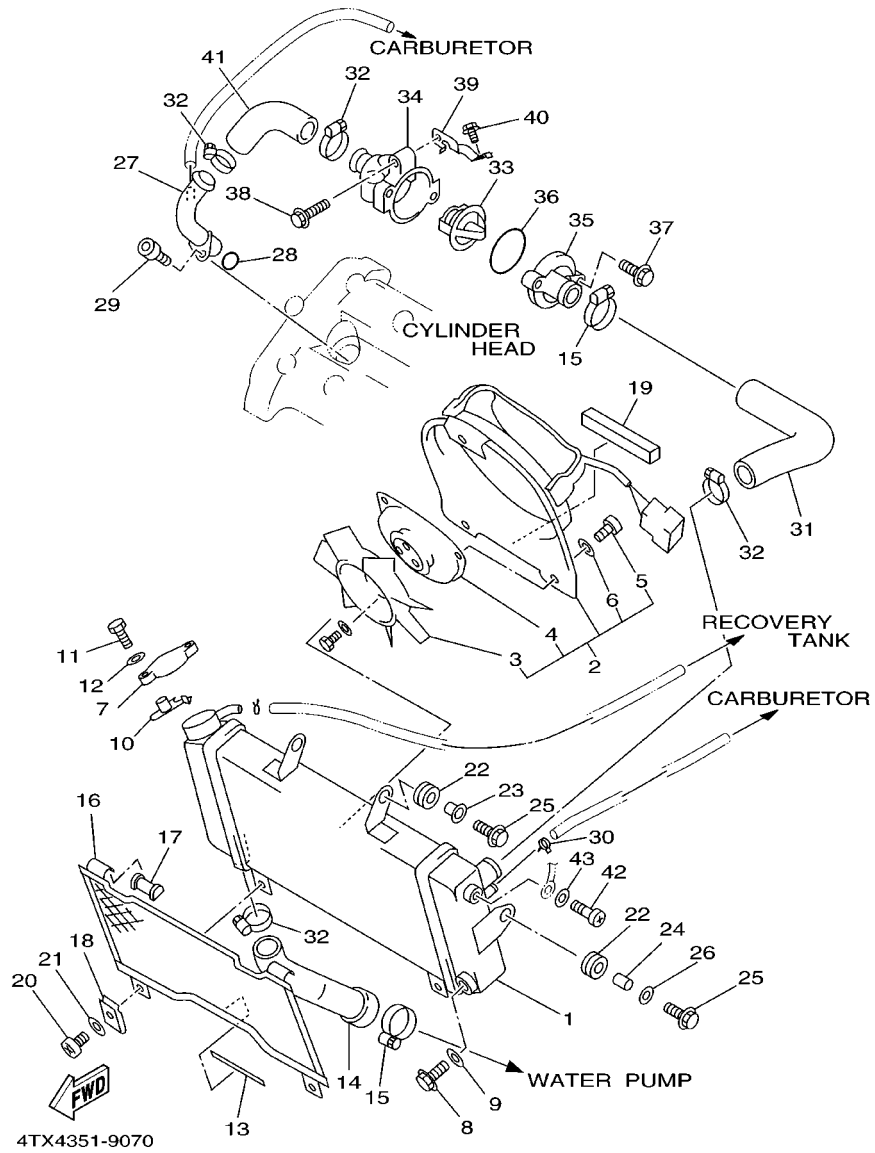

REF. NO.	PART NO.	DESCRIPTION	4TX8	4TX9	REMARKS
28	93210-18417	O-RING	1	1	
29	91317-06016	BOLT	1	1	
30	90467-11090	CLIP	1	1	
31	4TX-12576-40	HOSE 1	1	1	
32	90450-32015	HOSE CLAMP ASSY	4	4	
33	1AE-12410-00	THERMOSTAT ASSY	1	1	
34	4TX-12417-40	HOUSING, THERMOSTAT	1	1	
35	4NX-12413-00	COVER, THERMOSTAT	1	1	
36	93210-49046	O-RING	1	1	
37	95027-06020	BOLT, FLANGE	2	2	
38	95027-06025	BOLT, FLANGE	1	1	
39	4TX-1244E-00	BRACKET 1	1	1	
40	95027-06014	BOLT, FLANGE	1	1	
41	4NX-12579-00	HOSE 4	1	1	
42	98507-04008	SCREW, PAN HEAD	1	1	
43	92907-04600	WASHER	1	1	

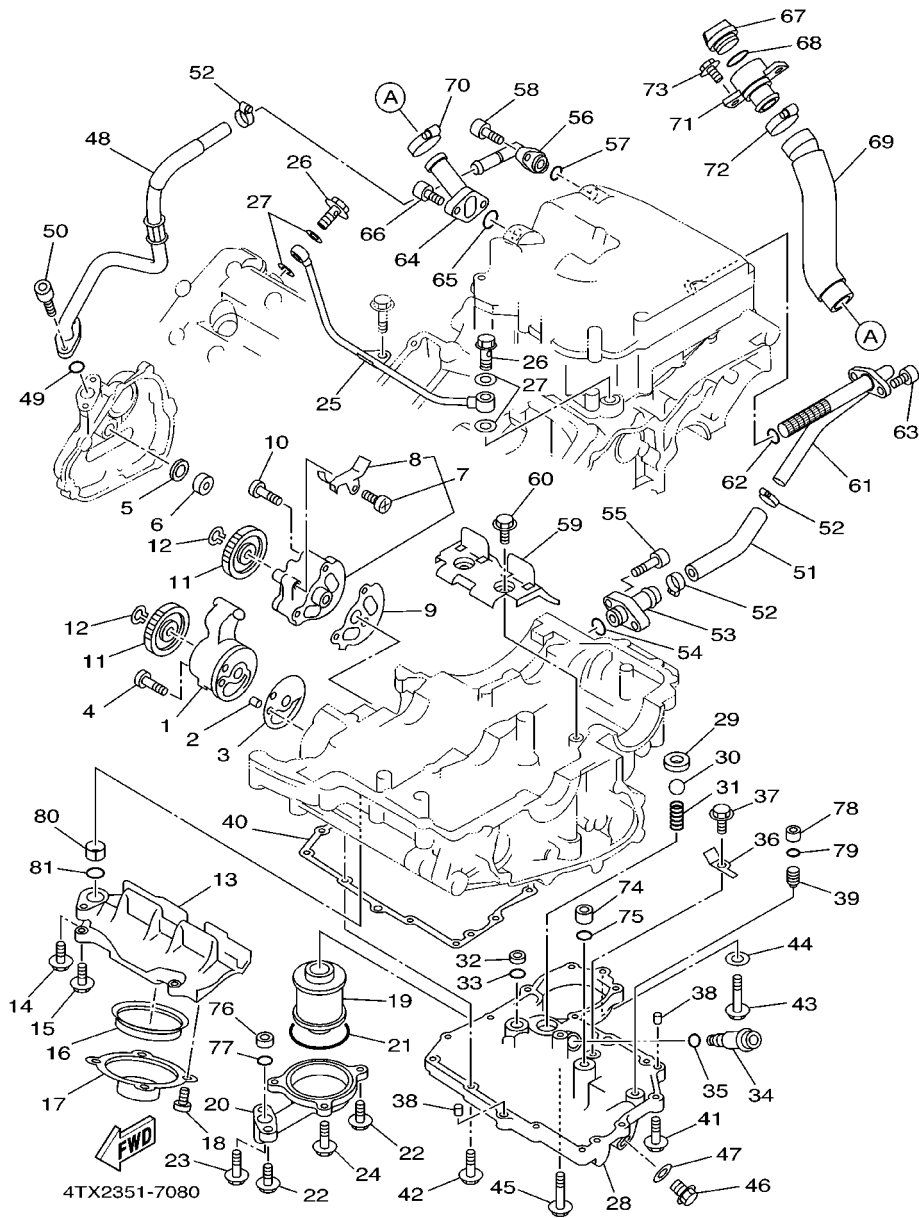

FIG. 8 OIL PUMP

REF. NO.	PART NO.	DESCRIPTION	4TX8	4TX9	REMARKS
1	3LD-13300-00	OIL PUMP ASSY	1	1	
2	99530-08012	PIN, DOWEL	1	1	
3	3LD-13329-00	GASKET, PUMP COVER	1	1	
4	98507-06045	SCREW, PAN HEAD	3	3	
5	90430-14131	GASKET	1	1	
6	90387-120W5	COLLAR	1	1	
7	4NX-13303-00	OIL PUMP ASSY, 2	1	1	
8	3LD-13371-00	.PLATE	1	1	
9	3LD-13339-00	GASKET, PUMP COVER	1	1	
10	98507-06035	SCREW, PAN HEAD	3	3	
11	3VD-13325-00	GEAR, PUMP DRIVEN	2	2	
12	99009-11400	CIRCLIP	2	2	
13	3VD-13412-00	HOUSING, STRAINER	1	1	
14	95027-06025	BOLT, FLANGE	1	1	
15	95027-06020	BOLT, FLANGE	4	4	
16	3VD-13415-00	SEAL, OIL STRAINER	1	1	
17	3VD-13411-00	STRAINER, OIL	1	1	
18	98507-06010	SCREW, PAN HEAD	4	4	
19	4X7-13440-01	ELEMENT ASSY, OIL CLEANER	1	1	
20	3VD-13447-00	COVER, OIL ELEMENT	1	1	
21	93210-64297	O-RING	1	1	
22	95024-06020	BOLT, FLANGE	2	2	
23	95024-06030	BOLT, FLANGE	1	1	
24	95024-06040	BOLT, FLANGE	2	2	
25	3LD-13161-00	PIPE, DELIVERY 1	1	1	
26	90401-10106	BOLT, UNION	2	2	
27	90430-10188	GASKET	4	4	

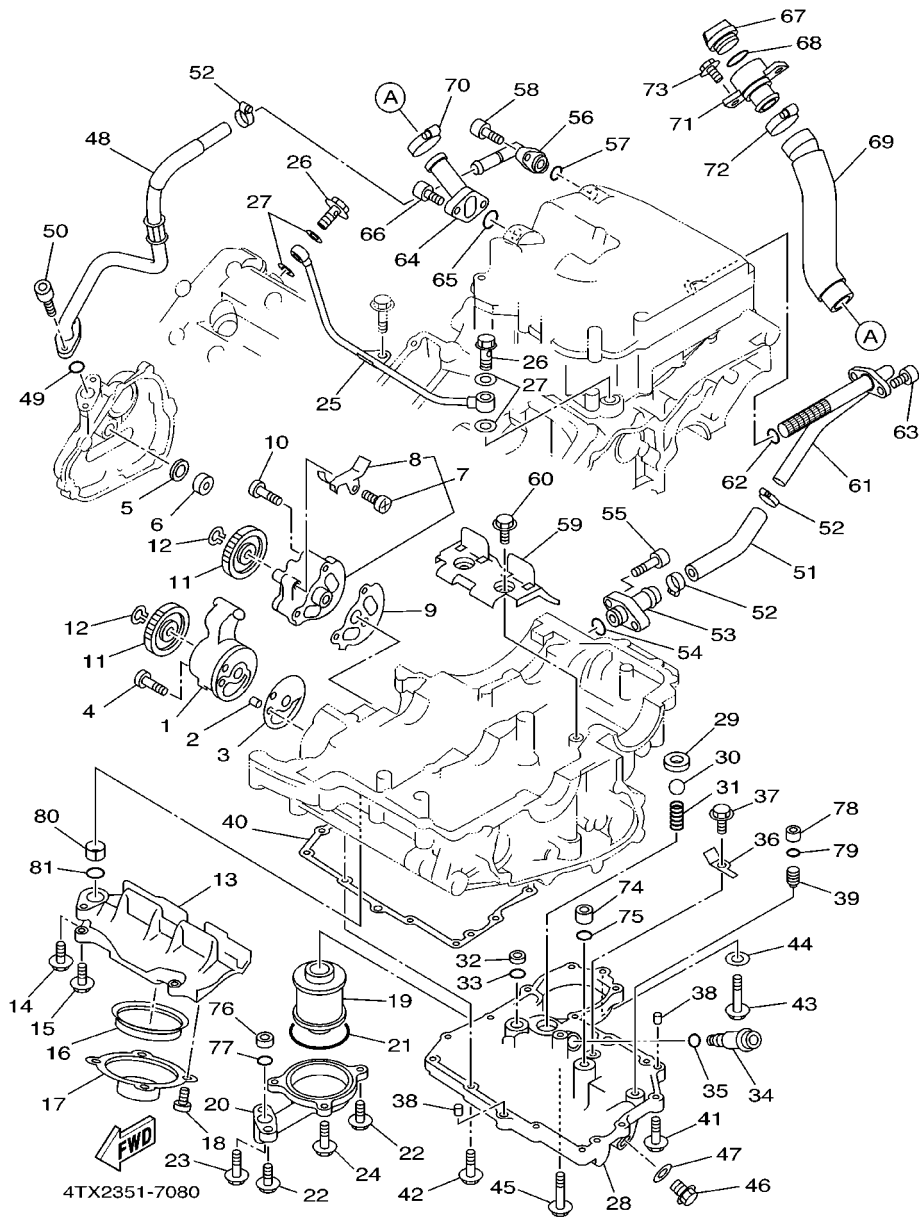

FIG. 8 OIL PUMP

REF. NO.	PART NO.	DESCRIPTION	4TX8	4TX9		REMARKS
28	3VD-13417-10	COVER, STRAINER	1	1		
29	3LD-13113-00	SEAT, CHECK BALL	1	1		
30	93505-08030	BALL	1	1		
31	90501-104F9	SPRING, COMPRESSION	1	1		
32	90387-106W6	COLLAR	1	1		
33	93210-12790	O-RING	1	1		
34	11H-13490-00	RELIEF VALVE ASSY	1	1		
35	93210-10096	O-RING	1	1		
36	3LD-13151-00	STAY	1	1		
37	90105-06553	BOLT, WASHER BASED	1	1		
38	99530-08016	PIN, DOWEL	2	2		
39	4H7-15138-00	NOZZLE 1	1	1		
40	3VD-13414-00	GASKET, STRAINER COVER	1	1		
41	90105-06456	BOLT, WASHER BASED	2	2		
42	95024-06025	BOLT, FLANGE	11	11		
43	95024-10040	BOLT, FLANGE	1	1		
44	90430-10188	GASKET	1	1		
45	95027-06035	BOLT, FLANGE	1	1		
46	90340-14132	PLUG, STRAIGHT SCREW	1	1		
47	214-11198-01	GASKET	1	1		
48	4UN-13464-01	HOSE, OIL 1	1	1		
49	93210-13657	O-RING	1	1		
50	91314-06020	BOLT	2	2		
51	4TX-13465-00	HOSE, OIL 2	1	1		
52	90460-27270	CLAMP, HOSE	3	3		
53	3VD-13416-00	PIPE, OIL 1	1	1		
54	93210-13657	O-RING	1	1		

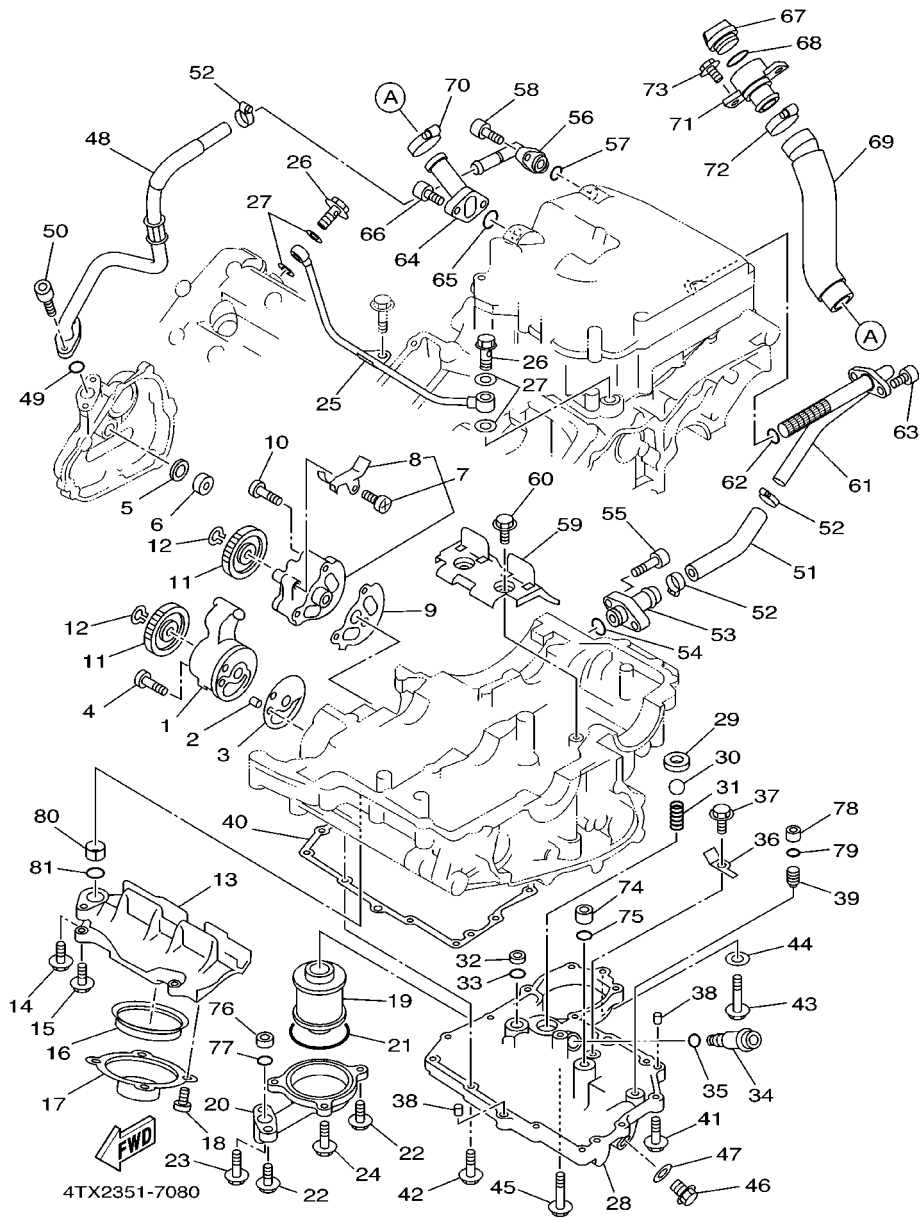
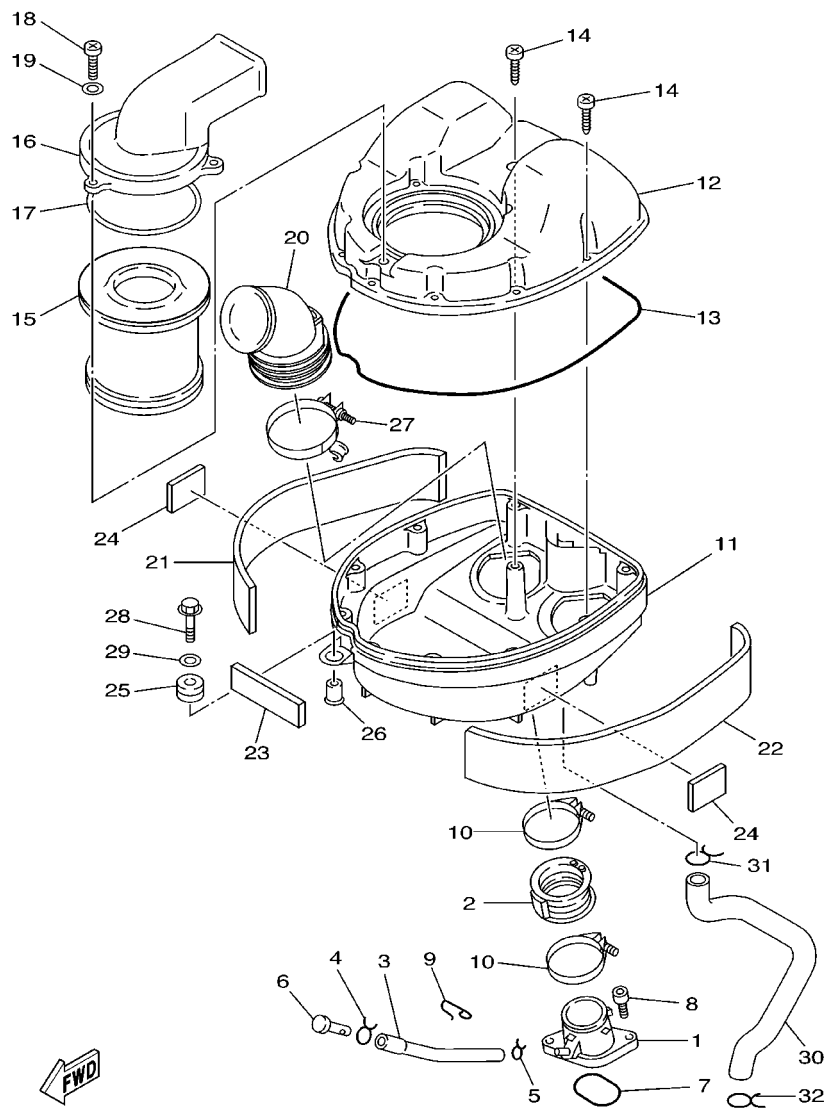

FIG. 8 OIL PUMP

REF. NO.	PART NO.	DESCRIPTION	4TX8	4TX9	REMARKS
55	90110-06093	BOLT, HEXAGON SOCKET HEAD	2	2	
56	4NX-13418-00	PIPE, OIL 2	1	1	
57	93210-13657	O-RING	1	1	
58	91314-06020	BOLT	2	2	
59	3VD-13317-00	PLATE, BAFFLE	1	1	
60	90105-06553	BOLT, WASHER BASED	2	2	
61	4TX-13416-00	PIPE, OIL 1	1	1	
62	93210-16629	O-RING	1	1	
63	91314-06020	BOLT	2	2	
64	4TX-13132-00	JOINT	1	1	
65	93210-26741	O-RING	1	1	
66	91314-06025	BOLT	2	2	
67	3F9-15362-00	PLUG, OIL LEVEL	1	1	
68	93210-27370	O-RING	1	1	
69	4TX-13467-00	HOSE	1	1	
70	90450-32015	HOSE CLAMP ASSY	1	1	
71	4TX-13266-00	CONNECTOR, OIL	1	1	
72	90450-38040	HOSE CLAMP ASSY	1	1	
73	95027-06016	BOLT, FLANGE	2	2	
74	90387-085N0	COLLAR	1	1	
75	93210-10096	O-RING	1	1	
76	90387-106W6	COLLAR	1	1	
77	93210-12790	O-RING	1	1	
78	90387-06761	COLLAR	1	1	
79	93210-07135	O-RING	1	1	
80	90387-130W6	COLLAR	1	1	
81	93210-15566	O-RING	1	1	

FIG. 9 INTAKE



4TX4351-9090

REF. NO.	PART NO.	DESCRIPTION	4TX8	4TX9				REMARKS
1	3LD-13586-01	JOINT, CARBURETOR 1	2	2				
2	3LD-13597-01	JOINT, CARBURETOR 3	2	2				
3	90445-090E5	HOSE (L410)	2	2				
4	90467-08017	CLIP	2	2				
5	90467-08075	CLIP	2	2				
6	90338-05194	PLUG	2	2				
7	93210-44545	O-RING	2	2				
8	91317-06020	BOLT	4	4				
9	90465-20035	CLAMP	1	1				
10	90450-57034	HOSE CLAMP ASSY	4	4				
11	4TX-14411-40	CASE, AIR CLEANER 1	1	1				
12	3VD-14421-00	CASE, AIR CLEANER 2	1	1				
13	4BR-14452-00	SEAL	1	1				
14	97707-50125	SCREW, TAPPING	10	10				
15	1AE-14451-00	ELEMENT, AIR CLEANER	1	1				
16	3VD-14422-00	CAP, CLEANER CASE 2	1	1				
17	1AE-14452-00	SEAL	1	1				
18	98507-05016	SCREW, PAN HEAD	3	3				
19	92907-05600	WASHER, PLATE	3	3				
20	4TX-14453-40	JOINT, AIR CLEANER 1	2	2				
21	4TX-14425-40	DAMPER 1	1	1				
22	4TX-14426-40	DAMPER 2	1	1				
23	3VD-1442G-00	DAMPER 3	1	1				
24	4N0-24181-00	DAMPER, LOCATING 1	2	2				
25	90480-14604	GROMMET	1	1				
26	90387-07391	COLLAR	1	1				
27	90450-75083	HOSE CLAMP ASSY	2	2				

FIG. 9 INTAKE

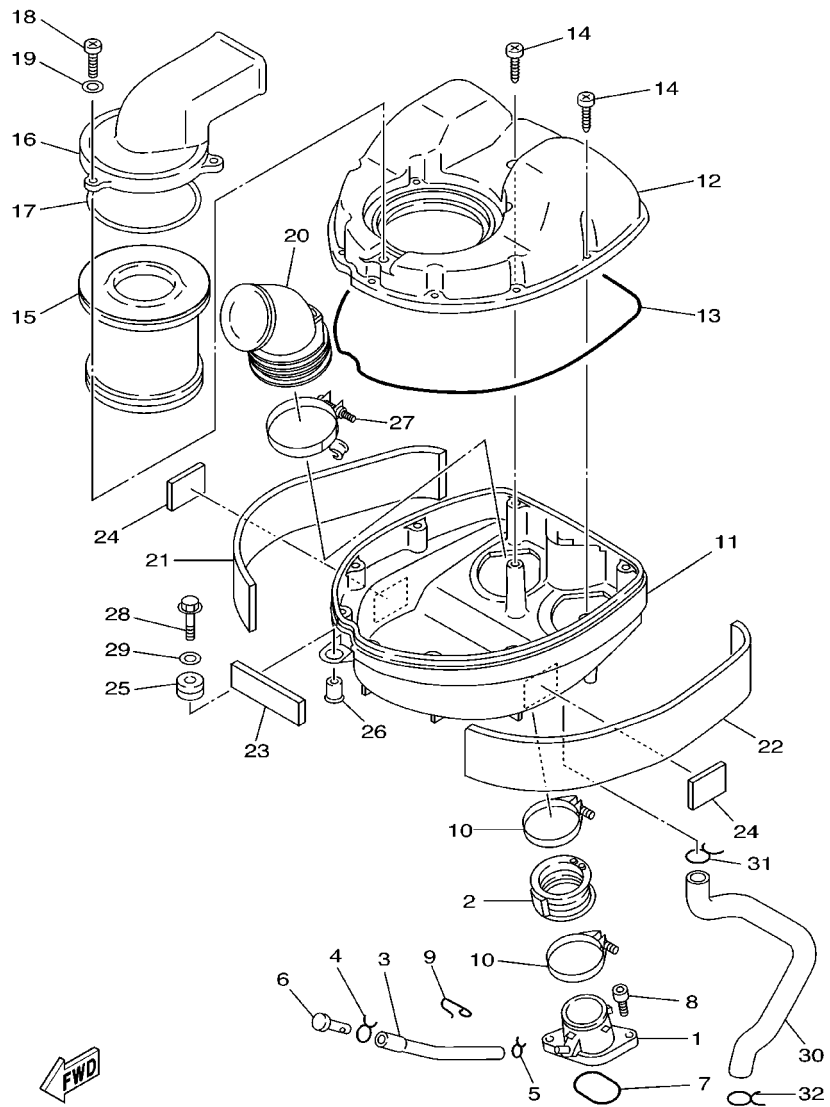

4TX4351-9090

REF. NO.	PART NO.	DESCRIPTION	4TX8	4TX9				REMARKS
28	97007-06025	BOLT	1	1				
29	90201-06063	WASHER, PLATE	1	1				
30	4TX-11166-01	PIPE, BREATHER 1	1	1				
31	90467-22080	CLIP	1	1				
32	90467-24113	CLIP	1	1				

FIG. 10 CARBURETOR

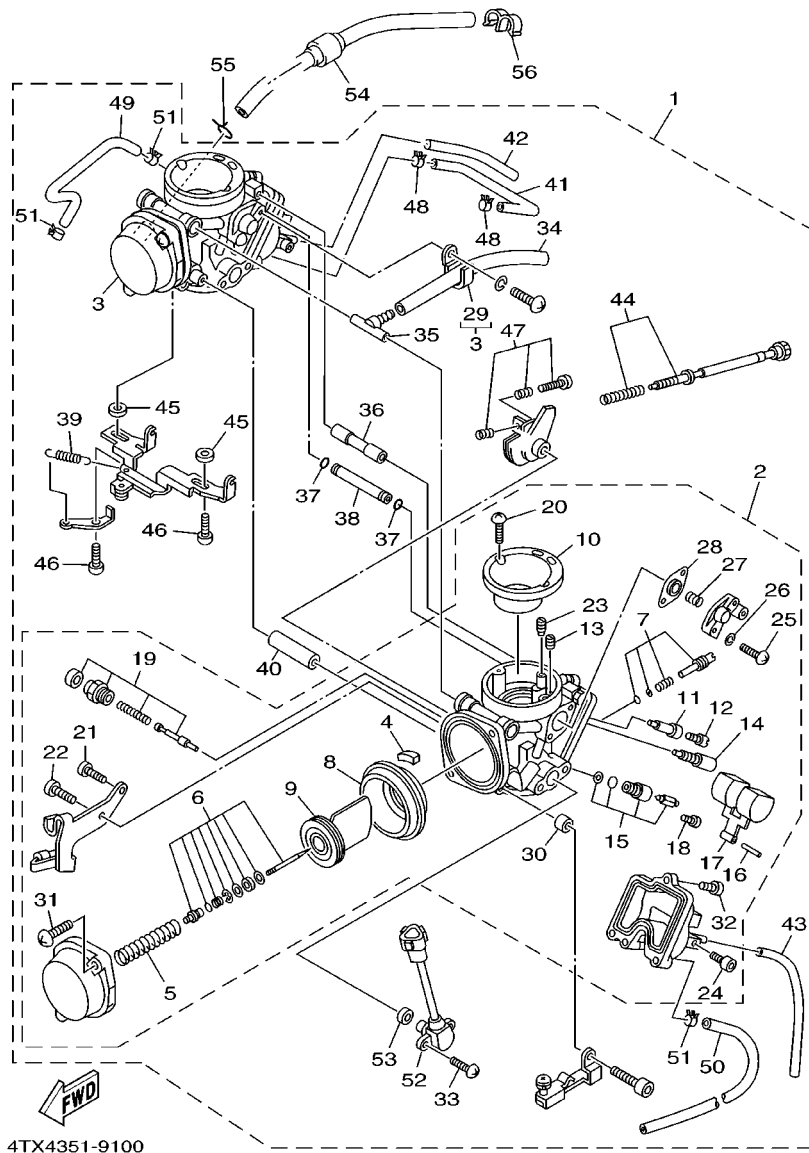

4TX4351-9100

REF. NO.	PART NO.	DESCRIPTION	4TX8	4TX9	REMARKS
1	4TX-14900-40	CARBURETOR ASSY	1	1	
2	4TX-14901-40	..CARBURETOR ASSY 1	1	1	
3	4TX-14902-40	..CARBURETOR ASSY 2	1	1	
4	4SV-14968-00	..CAP	1	1	
5	4TX-14275-00	..SPRING	1	1	
6	4TX-1490J-40	..NEEDLE SET	1	1	UR #1
	4TX-1490J-50	..NEEDLE SET	1	1	UR #2
7	5DM-14105-00	..PILOT SCREW SET	1	1	
8	4SV-24411-00	..DIAPHRAGM	1	1	
9	4SV-14112-00	..VALVE, THROTTLE 1	1	1	
10	4TX-14479-00	..FUNNEL	1	1	
11	4TX-14261-00	..HOLDER	1	1	
12	3G2-1423A-80	..JET, MAIN (#147.5)	1	1	
13	1HX-1423A-68	..JET, MAIN (#87.5)	1	1	
14	4KM-14142-17	..JET, PILOT (#17.5)	1	1	
15	4KM-14107-15	..NEEDLE VALVE SET	1	1	
16	620-14186-00	..PIN, FLOAT	1	1	
17	4SV-14985-00	..FLOAT	1	1	
18	1FN-14565-00	..SCREW	1	1	
19	4SV-1410A-00	..STARTER SET	1	1	
20	98507-04018	..SCREW, PAN HEAD	2	2	
21	98507-04008	..SCREW, PAN HEAD	1	1	
22	98507-05010	..SCREW, PAN HEAD	1	1	
23	1HX-14231-24	..JET, MAIN (#120)	1	1	
24	4KP-14191-00	..PLUG, DRAIN	1	1	
25	98507-04014	..SCREW, PAN HEAD	2	2	
26	92907-04100	..WASHER, SPRING	2	2	

FIG. 10 CARBURETOR

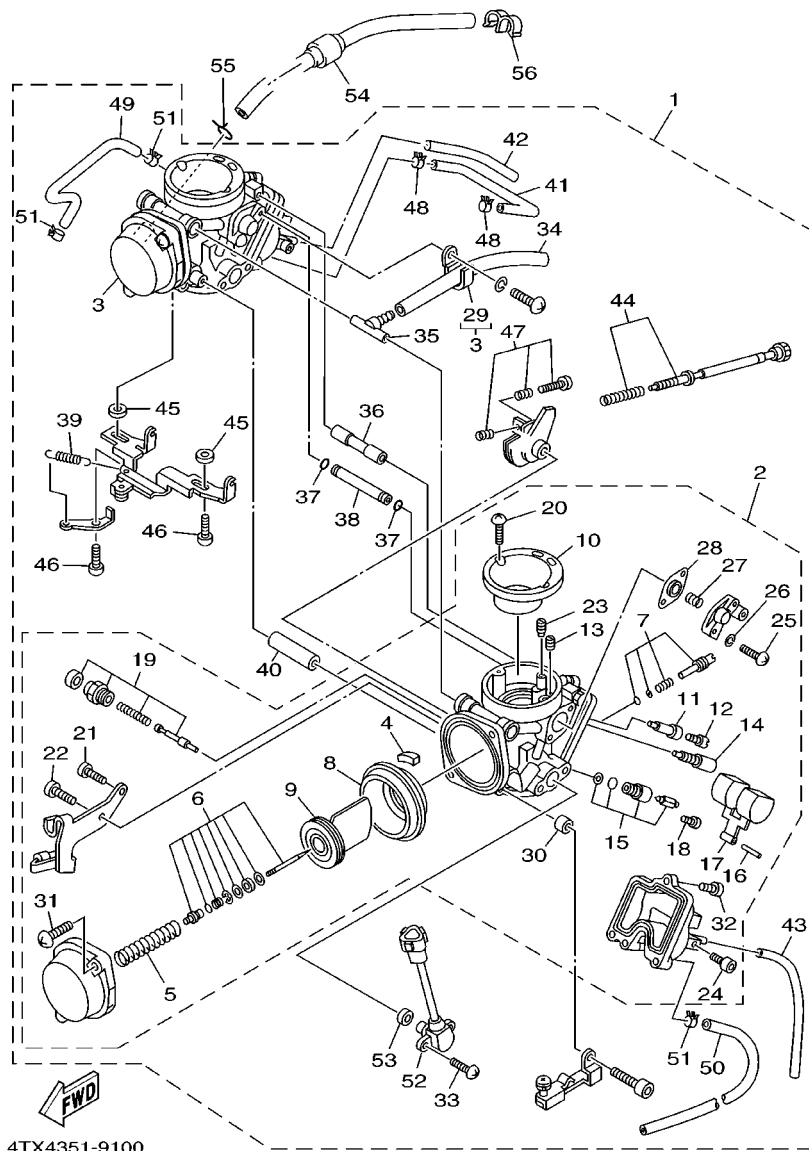

4TX4351-9100

REF. NO.	PART NO.	DESCRIPTION	4TX8	4TX9	REMARKS
27	4XY-14589-00	..SPRING	1	1	
28	5AP-14940-00	..DIAPHRAGM ASSY	1	1	
29	90461-06087	..CLAMP	1	1	
30	4TX-14264-00	..COLLAR	1	1	
31	4KM-14216-00	..SCREW	2	2	
32	98507-05012	..SCREW, PAN HEAD	3	3	
33	4WM-14565-00	..SCREW	2	2	
34	4TX-14348-00	..PIPE 1	1	1	
35	4SV-14987-00	..HOSE	1	1	
36	4TX-14148-10	..PIPE	1	1	
37	36Y-14147-00	..O-RING	2	2	
38	4TX-14419-00	..PIPE	1	1	
39	4SV-14935-00	..SPRING	1	1	
40	4TX-14148-00	..PIPE	1	1	
41	4TX-14349-00	..PIPE	1	1	
42	3JE-14197-00	..PIPE	1	1	
43	3JD-14197-00	..PIPE	1	1	
44	4TX-14103-40	..THROTTLE SCREW SET	1	1	
45	4NK-14327-00	..PACKING	2	2	
46	4XV-24453-00	..SCREW	2	2	
47	3EN-1490K-00	..STOP SCREW SET	1	1	
48	5DM-14919-00	..CLIP	2	2	
49	4TX-1243A-40	..HOSE 1	1	1	
50	4TX-1243F-40	..HOSE,3	1	1	
51	90467-09037	..CLIP	3	3	
52	4TX-85885-00	..THROTTLE SENSOR ASSY	1	1	
53	4HM-14239-00	..SEAL	1	1	

FIG. 12 CRANKCASE

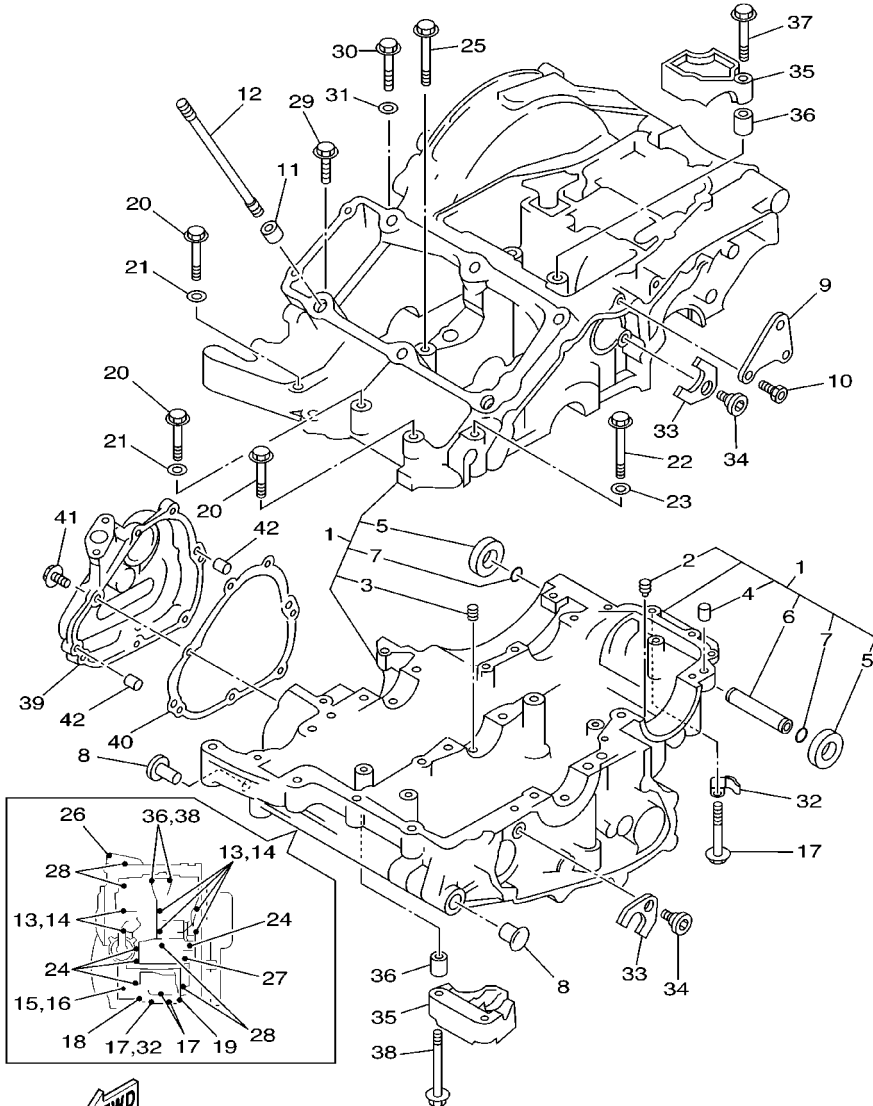

4TX1351-6120

REF. NO.	PART NO.	DESCRIPTION	4TX8	4TX9	REMARKS
1	3VD-15100-23	CRANKCASE ASSY	1	1	
2	2H7-15138-00	.NOZZLE 1	1	1	
3	4G0-15138-00	.NOZZLE 1	1	1	
4	99530-10114	.PIN, DOWEL	1	1	
5	3VD-15316-00	.DAMPER, ENGINE MOUNT 1	2	2	
6	3VD-15317-00	.SPACER, ENGINE MOUNT	1	1	
7	93210-12095	.O-RING	2	2	
8	90338-11257	PLUG	2	2	
9	3VD-15199-00	BRACKET	1	1	
10	91314-08016	BOLT	2	2	
11	99530-14016	PIN, DOWEL	2	2	
12	3LD-11361-00	BOLT, CYLINDER HOLDING 1	6	6	
13	90105-10560	BOLT, WASHER BASED	6	6	
14	90201-11597	WASHER, PLATE	6	6	
15	95814-06040	BOLT, FLANGE	1	1	
16	90201-066F0	WASHER, PLATE	1	1	
17	95817-06055	BOLT, FLANGE	3	3	
18	95817-06020	BOLT, FLANGE	1	1	
19	95817-06030	BOLT, FLANGE	1	1	
20	95814-08050	BOLT, FLANGE	3	3	
21	90201-08087	WASHER, PLATE	2	2	
22	95814-08060	BOLT, FLANGE	1	1	
23	90201-08087	WASHER, PLATE	1	1	
24	95817-06070	BOLT, FLANGE	4	4	
25	95817-08065	BOLT, FLANGE	1	1	
26	95814-08050	BOLT, FLANGE	1	1	
27	95817-08070	BOLT, FLANGE	1	1	

FIG. 12 CRANKCASE

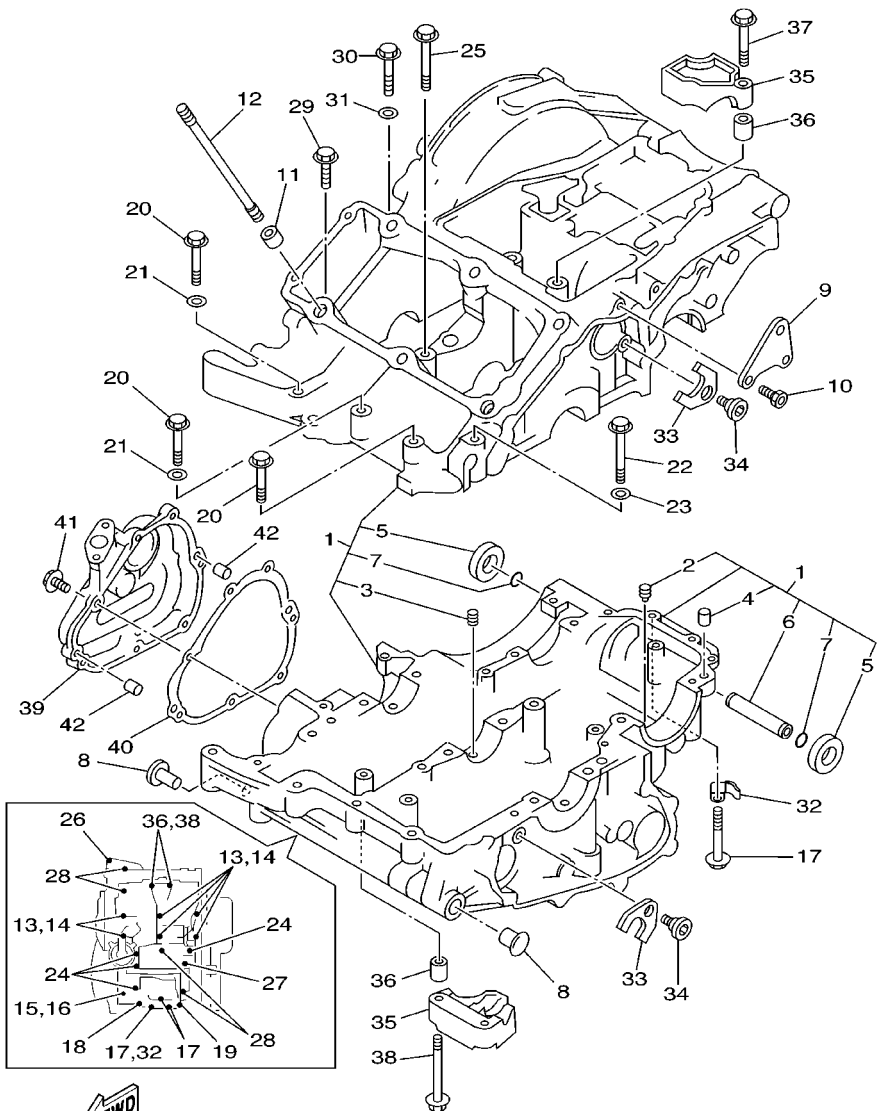

4TX1351-6120

REF. NO.	PART NO.	DESCRIPTION	4TX8	4TX9				REMARKS
28	95817-08075	BOLT, FLANGE	4	4				
29	95817-06025	BOLT, FLANGE	1	1				
30	95814-06040	BOLT, FLANGE	1	1				
31	90201-066F0	WASHER, PLATE	1	1				
32	90465-08341	CLAMP	1	1				
33	3LD-15191-00	PLATE	2	2				
34	90149-06285	SCREW	2	2				
35	3LD-15118-00	HOLDER	2	2				
36	99530-08016	PIN, DOWEL	4	4				
37	95817-06045	BOLT, FLANGE	2	2				
38	95817-06070	BOLT, FLANGE	2	2				
39	3VD-15416-10	COVER, OIL PUMP	1	1				
40	3VD-15456-00	GASKET, OIL PUMP COVER 1	1	1				
41	95024-06020	BOLT, FLANGE	7	7				
42	99530-08012	PIN, DOWEL	2	2				

FIG. 13 CRANKCASE COVER 1

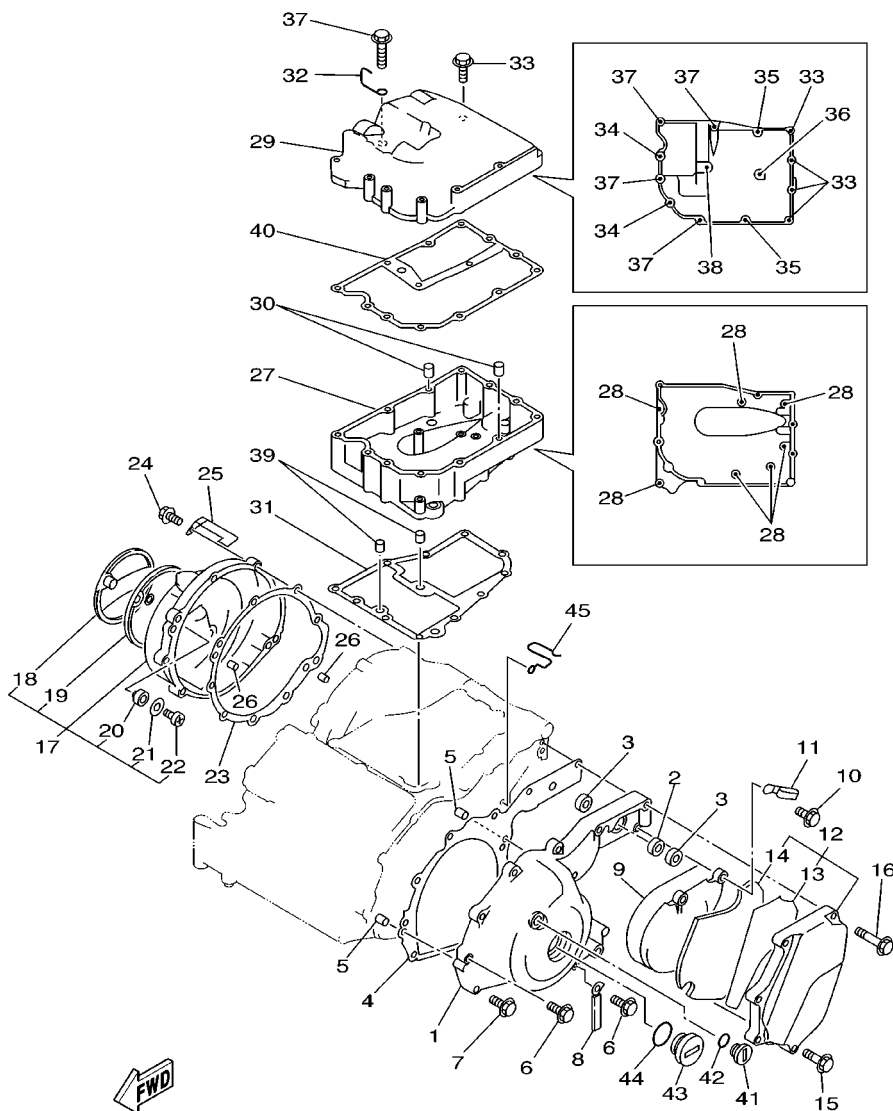

4TX4351-9130

REF. NO.	PART NO.	DESCRIPTION	4TX8	4TX9	REMARKS
1	3VD-15411-11	COVER, CRANKCASE 1	1	1	
2	93317-21236	BEARING	1	1	
3	93109-12075	OIL SEAL	2	2	
4	3VD-15451-00	GASKET, CRANKCASE COVER 1	1	1	
5	99530-08012	PIN, DOWEL	2	2	
<hr/>					
6	95024-06025	BOLT, FLANGE	8	8	
7	90105-06456	BOLT, WASHER BASED	1	1	
8	90465-08127	CLAMP	1	1	
9	3LD-15418-00	COVER, CHAIN CASE	1	1	
10	95027-06025	BOLT, FLANGE	2	2	
<hr/>					
11	90465-08122	CLAMP	1	1	
12	3VD-15420-01	CRANKCASE COVER ASSY 2	1	1	
13	3VD-15326-00	.DAMPER, ENGINE MOUNT 2	1	1	
14	3VD-15335-00	.DAMPER 3	1	1	
15	95024-06030	BOLT, FLANGE	1	1	
<hr/>					
16	95024-06055	BOLT, FLANGE	4	4	
17	4UN-15430-00	CRANKCASE COVER ASSY 3	1	1	
18	3VD-15417-01	.COVER, CAP	1	1	
19	3LD-15449-00	.RING, RUBBER	1	1	
20	1JK-15486-00	.GROMMET	2	2	
<hr/>					
21	90209-05279	.WASHER	2	2	
22	98507-05010	.SCREW, PAN HEAD	2	2	
23	4NX-15462-01	GASKET, CRANKCASE COVER 3	1	1	
24	95024-06025	BOLT, FLANGE	9	9	
25	90465-15384	CLAMP	1	1	
<hr/>					
26	99530-08012	PIN, DOWEL	2	2	
27	4UN-15425-01	COVER, GENERATOR 2	1	1	

FIG. 13 CRANKCASE COVER 1

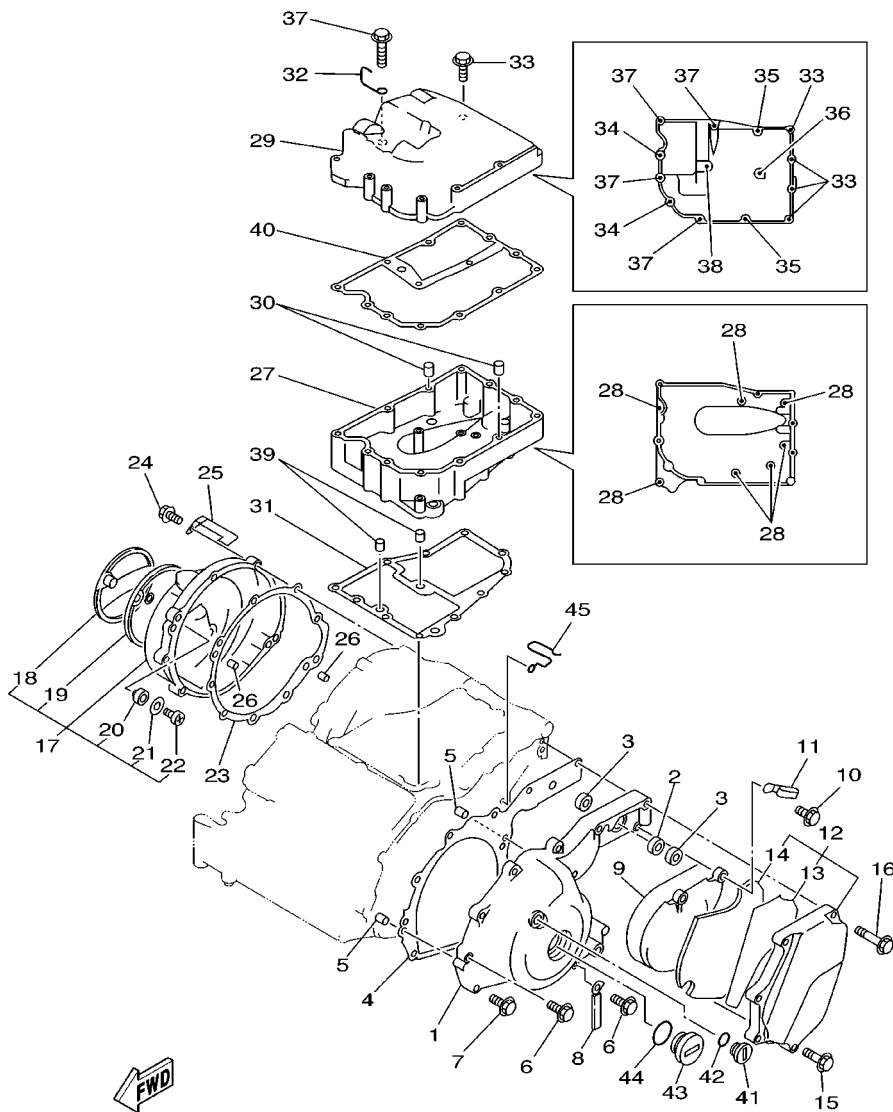

4TX4351-9130

REF. NO.	PART NO.	DESCRIPTION	4TX8	4TX9	REMARKS
28	95027-06035	BOLT, FLANGE	7	7	
29	4UN-15426-00	COVER, OIL PUMP 2	1	1	
30	99530-08012	PIN, DOWEL	2	2	
31	3VD-15463-00	GASKET, CARBURETOR COVER 2	1	1	
32	90462-20223	CLAMP	1	1	
33	95024-06035	BOLT, FLANGE	4	4	
34	95024-06045	BOLT, FLANGE	2	2	
35	95024-06055	BOLT, FLANGE	2	2	
36	90105-06131	BOLT, WASHER BASED	1	1	
37	95024-06110	BOLT, FLANGE	4	4	
38	95817-06090	BOLT, FLANGE	1	1	
39	99530-10114	PIN, DOWEL	2	2	
40	4NX-15461-00	GASKET, CRANKCASE COVER 2	1	1	
41	90340-14151	PLUG, STRAIGHT SCREW	1	1	
42	93210-14369	O-RING	1	1	
43	90340-32116	PLUG, STRAIGHT SCREW	1	1	
44	93210-32172	O-RING	1	1	
45	90465-20342	CLAMP	1	1	

FIG. 14 STARTER CLUTCH

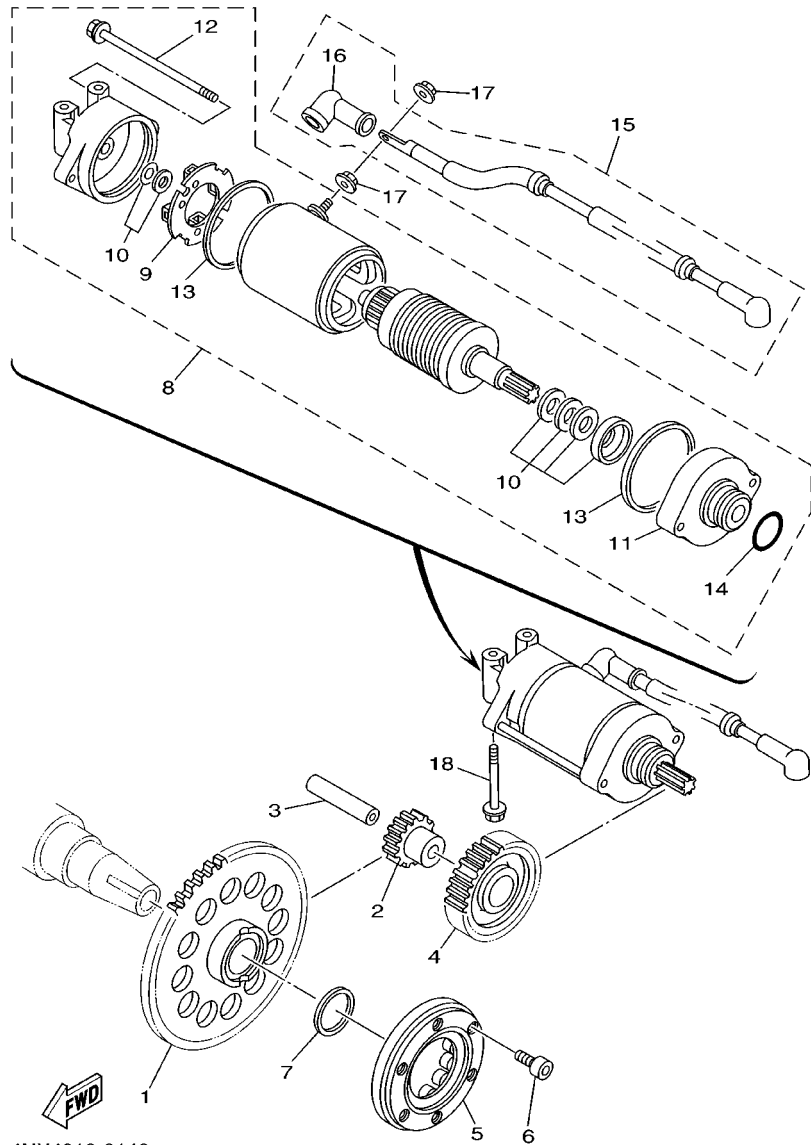

4NX4010-9140

REF. NO.	PART NO.	DESCRIPTION	4TX8	4TX9			REMARKS
1	4NX-15515-00	GEAR 3	1	1			
2	3LD-15517-00	GEAR, IDLER 2	1	1			
3	26H-15521-00	SHAFT 1	1	1			
4	3LD-15512-00	GEAR, IDLER 1	1	1			
5	3LD-15590-02	STARTER ONE-WAY ASSY	1	1			
6	91317-06018	BOLT	3	3			
7	90201-301P3	WASHER, PLATE	1	1			
8	3LD-81890-00	MOTOR ASSY	1	1			
9	3AJ-81801-00	.BRUSH SET	1	1			
10	3AJ-81809-00	.WASHER KIT	1	1			
11	3AJ-81830-00	.FRONT BRACKET ASSY	1	1			
12	3AJ-81826-00	.BOLT	2	2			
13	11H-81844-00	.GASKET	2	2			
14	1FK-81847-00	.O-RING	1	1			
15	3LD-81815-01	CORD, STARTER MOTOR	1	1			
16	4G0-81871-00	.CAP	1	1			
17	4XV-8182A-00	NUT	2	2			
18	95817-06050	BOLT, FLANGE	2	2			

FIG. 15 CLUTCH

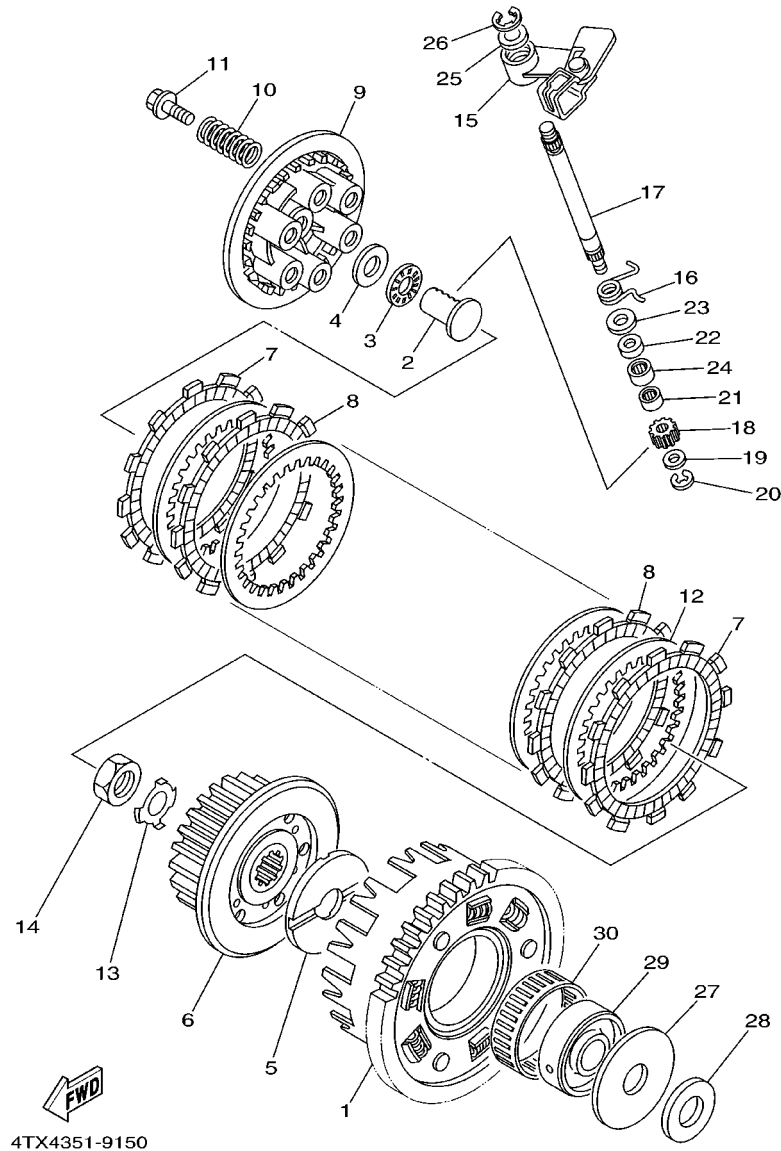

4TX4351-9150

REF. NO.	PART NO.	DESCRIPTION	4TX8	4TX9	REMARKS
1	4TX-16150-01	PRIMARY DRIVEN GEAR COMP.	1	1	
2	3LD-1637A-01	ROD PUSH ASSY	1	1	
3	93340-21505	BEARING	1	1	
4	90201-150U6	WASHER, PLATE	1	1	
5	4H7-16154-00	PLATE, THRUST 1	1	1	
6	4TX-16371-00	BOSS, CLUTCH	1	1	
7	4H7-16321-02	PLATE, FRICTION	2	2	
8	4TX-16321-00	PLATE, FRICTION	7	7	
9	3LD-16351-00	PLATE, PRESSURE 1	1	1	
10	90501-237L0	SPRING, COMPRESSION	6	6	
11	90159-06123	SCREW, WITH WASHER	6	6	
12	3J2-16324-00	PLATE, CLUTCH 1	8	8	
13	90215-20231	WASHER, LOCK	1	1	
14	90170-20327	NUT	1	1	
15	4TX-16340-40	PUSH LEVER ASSY	1	1	
16	90508-167A3	SPRING, TORSION	1	1	
17	3LD-16382-00	AXLE, PUSH LEVER	1	1	
18	3LD-16398-00	PINION, RELEAS	1	1	
19	92907-08600	WASHER, PLATE	1	1	
20	99001-07600	CIRCLIP	1	1	
21	93317-11020	BEARING	1	1	
22	93102-12224	OIL SEAL	1	1	
23	90201-12163	WASHER, PLATE	1	1	
24	93315-11206	BEARING	1	1	
25	90201-10119	WASHER, PLATE	1	1	
26	99009-10400	CIRCLIP	1	1	
27	3VD-16164-00	PLATE, THRUST 2	1	1	

FIG. 15 CLUTCH

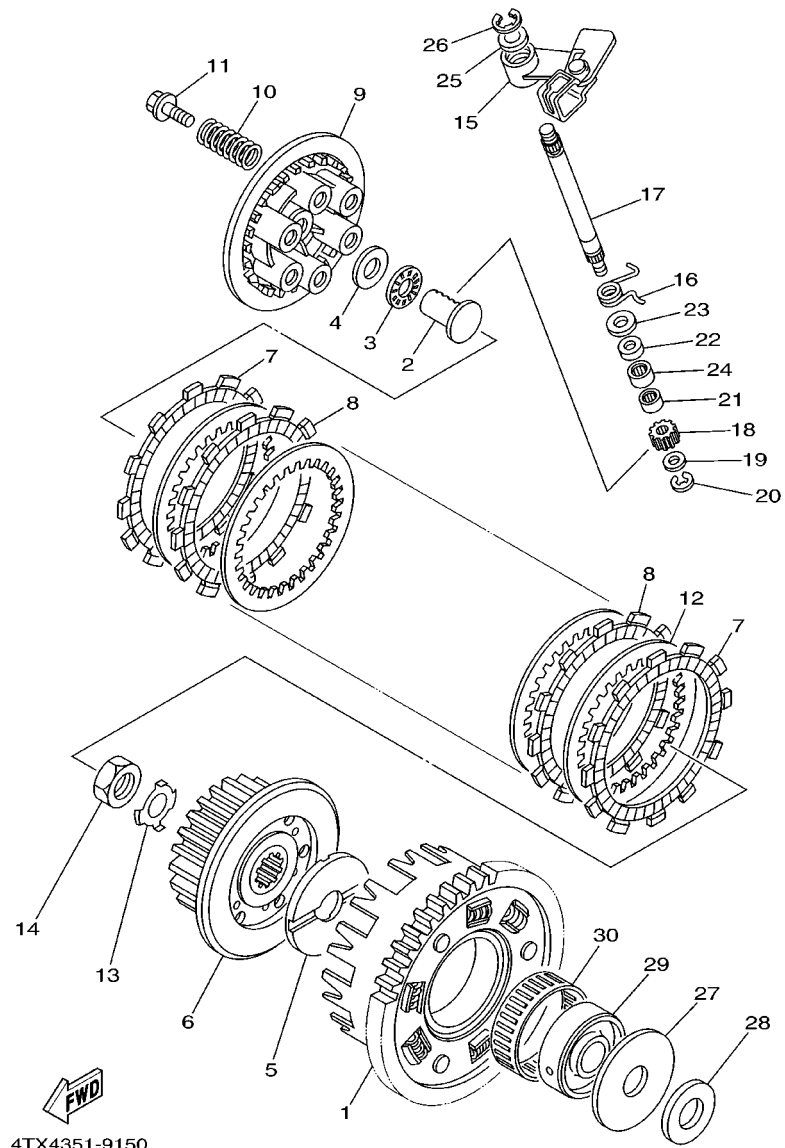

4TX4351-9150

REF. NO.	PART NO.	DESCRIPTION	4TX8	4TX9				REMARKS
28	3VD-16154-00	PLATE, THRUST 1	1	1				
29	4NX-16181-00	SPACER 1	1	1				
30	93310-365B8	BEARING	1	1				

FIG. 16 TRANSMISSION

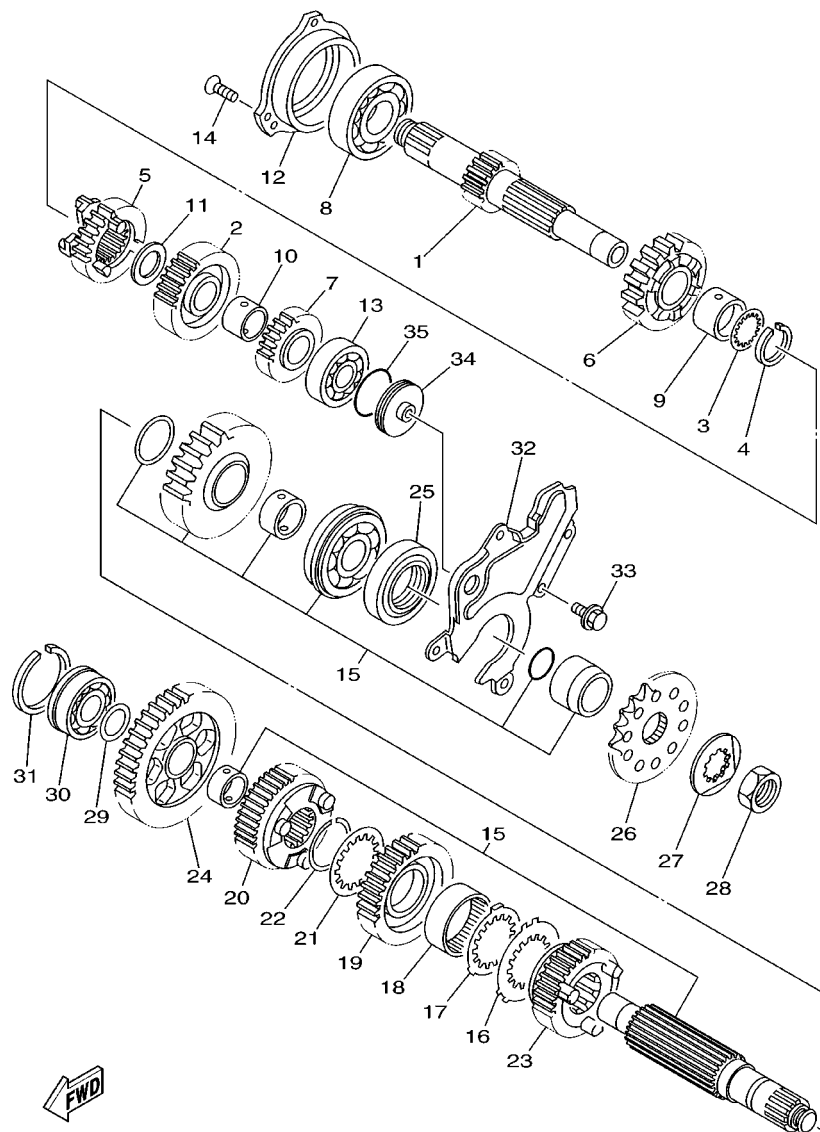

4TX4351-9160

REF. NO.	PART NO.	DESCRIPTION	4TX8	4TX9	REMARKS
1	4TX-17411-40	AXLE, MAIN	1	1	
2	4TX-17151-40	GEAR, 5TH PINION (28T)	1	1	
3	90209-21332	WASHER	1	1	
4	93440-25084	CIRCLIP	1	1	
5	4TX-17131-40	GEAR, 3RD PINION (20T)	1	1	
6	2GH-17141-00	GEAR, 4TH PINION (23T)	1	1	
7	4TX-17121-40	GEAR, 2ND PINION (19T)	1	1	
8	93306-30525	BEARING (B6305)	1	1	
9	90387-253M6	COLLAR	1	1	
10	90387-203M7	COLLAR	1	1	
11	90201-200K3	WASHER, PLATE	1	1	
12	3LD-15163-10	HOUSING, BEARING 1	1	1	
13	93306-20464	BEARING	1	1	
14	90149-06286	SCREW	3	3	
15	4TX-17402-40	DRIVE AXLE ASSY	1	1	
16	90209-29329	WASHER	1	1	
17	90209-28330	WASHER	1	1	
18	90387-2802W	COLLAR	1	1	
19	4TX-17231-40	GEAR, 3RD WHEEL (30T)	1	1	
20	4NX-17241-00	GEAR, 4TH WHEEL (27T)	1	1	
21	90209-28331	WASHER	1	1	
22	93440-31172	CIRCLIP	1	1	
23	4TX-17251-40	GEAR, 5TH WHEEL (27T)	1	1	
24	4TX-17211-40	GEAR, 1ST WHEEL (37T)	1	1	
25	93102-35459	OIL SEAL	1	1	
26	9384E-16191	SPRÖCKĚT, DRIVE (16T)	1	1	
27	90215-21290	WASHER, LOCK	1	1	

FIG. 17 SHIFT CAM. FORK

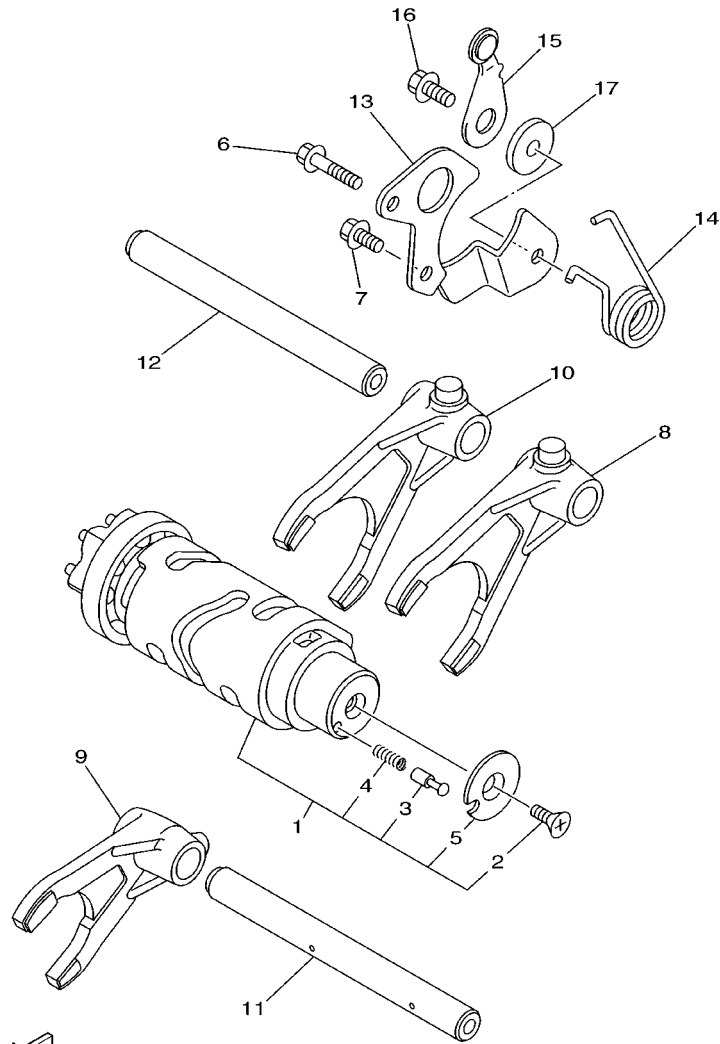

4TX4351-9170

REF. NO.	PART NO.	DESCRIPTION	4TX8	4TX9				REMARKS
1	4TX-18540-40	SHIFT CAM ASSY	1	1				
2	90149-05321	.SCREW	1	1				
3	4UN-18542-00	.POINT, NEUTRAL	1	1				
4	90501-06022	.SPRING, COMPRESSION	1	1				
5	4UN-18566-00	.PLATE, SIDE 2	1	1				
6	90105-06597	BOLT, WASHER BASED	1	1				
7	90105-06397	BOLT, WASHER BASED	1	1				
8	3VD-18511-00	FORK, SHIFT 1	1	1				
9	3VD-18512-00	FORK, SHIFT 2	1	1				
10	3VD-18513-00	FORK, SHIFT 3	1	1				
11	4NX-18531-00	BAR, SHIFT FORK GUIDE 1	1	1				
12	4NX-18535-00	BAR, SHIFT FORK GUIDE 2	1	1				
13	3LD-18536-00	STOPPER, SHIFT BAR	1	1				
14	90508-297A4	SPRING, TORSION	1	1				
15	4SV-18140-00	STOPPER LEVER ASSY	1	1				
16	90105-06557	BOLT, WASHER BASED	1	1				
17	4NX-18175-00	SPACER	1	1				

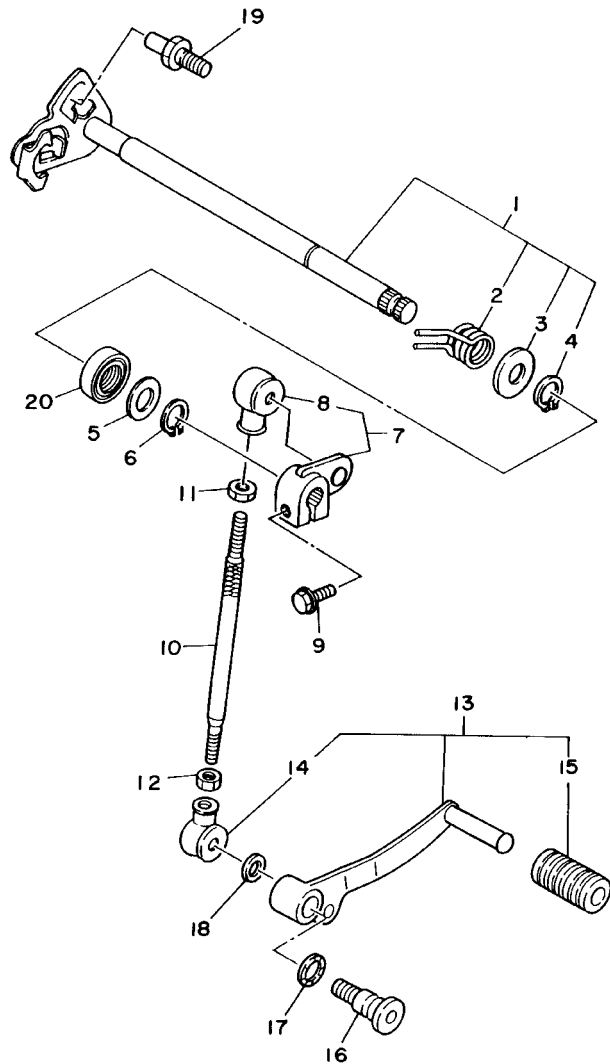

3VD1351-1180

FIG. 18 SHIFT SHAFT

REF. NO.	PART NO.	DESCRIPTION	4TX8	4TX9			REMARKS
1	3LD-18101-02	SHIFT SHAFT ASSY	1	1			
2	90508-32682	.SPRING, TORSION	1	1			
3	90201-191J4	.WASHER, PLATE	1	1			
4	99009-19400	.CIRCLIP	1	1			
5	90201-12575	WASHER, PLATE	1	1			
6	99001-10600	CIRCLIP	1	1			
7	3LD-18130-00	SHIFT SHAFT ASSY	1	1			
8	2H9-18154-00	.COVER, DUST	1	1			
9	95827-06020	BOLT, FLANGE	1	1			
10	3VD-18115-00	ROD, SHIFT	1	1			
11	90170-06228	NUT (COUNTER CLOCKWISE)	1	1			
12	95304-06700	NUT	1	1			
13	3VD-18110-10	SHIFT PEDAL ASSY	1	1			
14	2H9-18154-00	.COVER, DUST	1	1			
15	132-18113-01	.COVER, SHIFT PEDAL	1	1			
16	2YK-27434-01	BOLT	1	1			
17	90206-12074	WASHER, WAVE	1	1			
18	90201-08326	WASHER, PLATE	1	1			
19	4G0-18127-00	STOPPER, SCREW	1	1			
20	93101-12004	OIL SEAL	1	1			

FIG. 19 FRAME

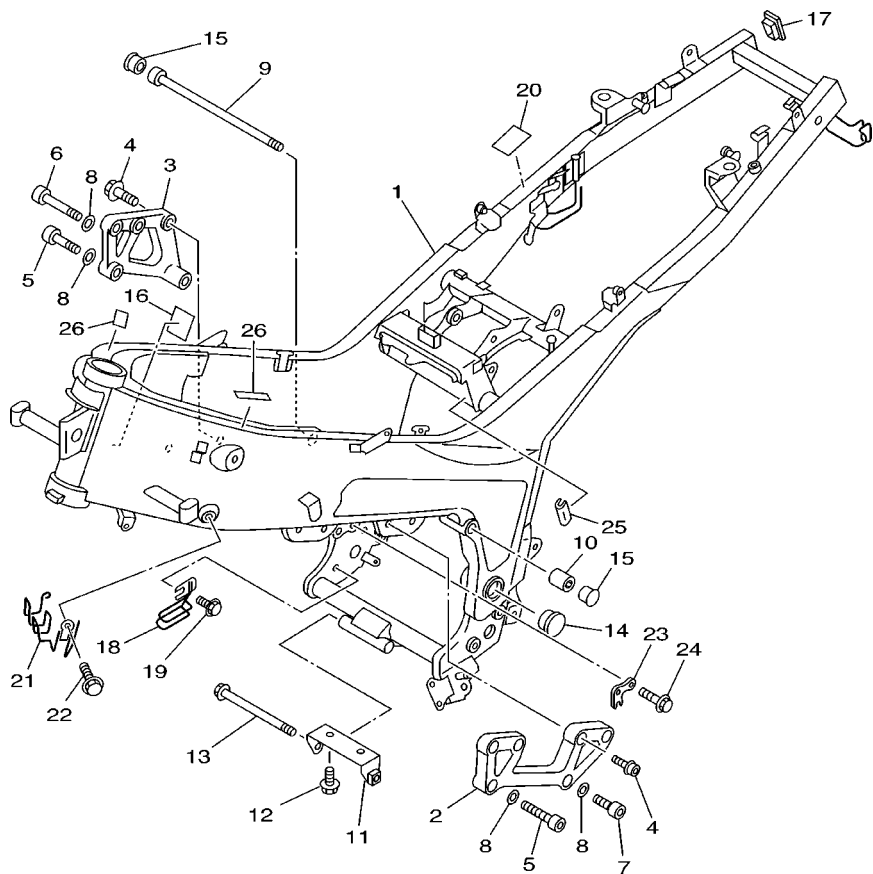

4TX4351-9190

REF. NO.	PART NO.	DESCRIPTION	4TX8	4TX9			REMARKS
1	4TX-21110-40-35	FRAME COMP.	1	1			SL
2	3VD-21411-10-35	BRACKET, ENGINE 1	1	1			SL
3	4TX-21419-00-35	BRACKET, ENGINE 2	1	1			SL
4	90109-083G1	BOLT	7	7			
5	91314-10045	BOLT	2	2			
6	91314-10060	BOLT	1	1			
7	91314-10025	BOLT	1	1			
8	90201-10430	WASHER, PLATE	4	4			
9	90110-10229	BOLT, HEXAGON SOCKET HEAD	1	1			
10	90179-10377	NUT	1	1			
11	3VD-21489-00	BRACKET, ENGINE LOWER	1	1			
12	90105-08752	BOLT, WASHER BASED	2	2			
13	90105-10328	BOLT, WASHER BASED	1	1			
14	4TX-2135F-01	COVER	2	2			
15	3LD-2143A-00	CAP	2	2			
16	11H-21747-00	DAMPER	1	1			
17	3VD-2143A-00	CAP	2	2			
18	3VD-21164-00	HOLDER, CABLE	1	1			
19	95807-06010	BOLT, FLANGE	1	1			
20	3YL-12232-00	DAMPER	1	1			
21	4TX-21161-00	HOLDER, CABLE	1	1			
22	90105-06446	BOLT, WASHER BASED	1	1			
23	4TX-2148U-40	BRACKET 1	1	1			
24	95024-06010	BOLT, FLANGE	2	2			
25	3YX-2171L-00	MOLE, SIDE COVER 1	1	1			
26	4KB-21268-00	SEAL	2	2			

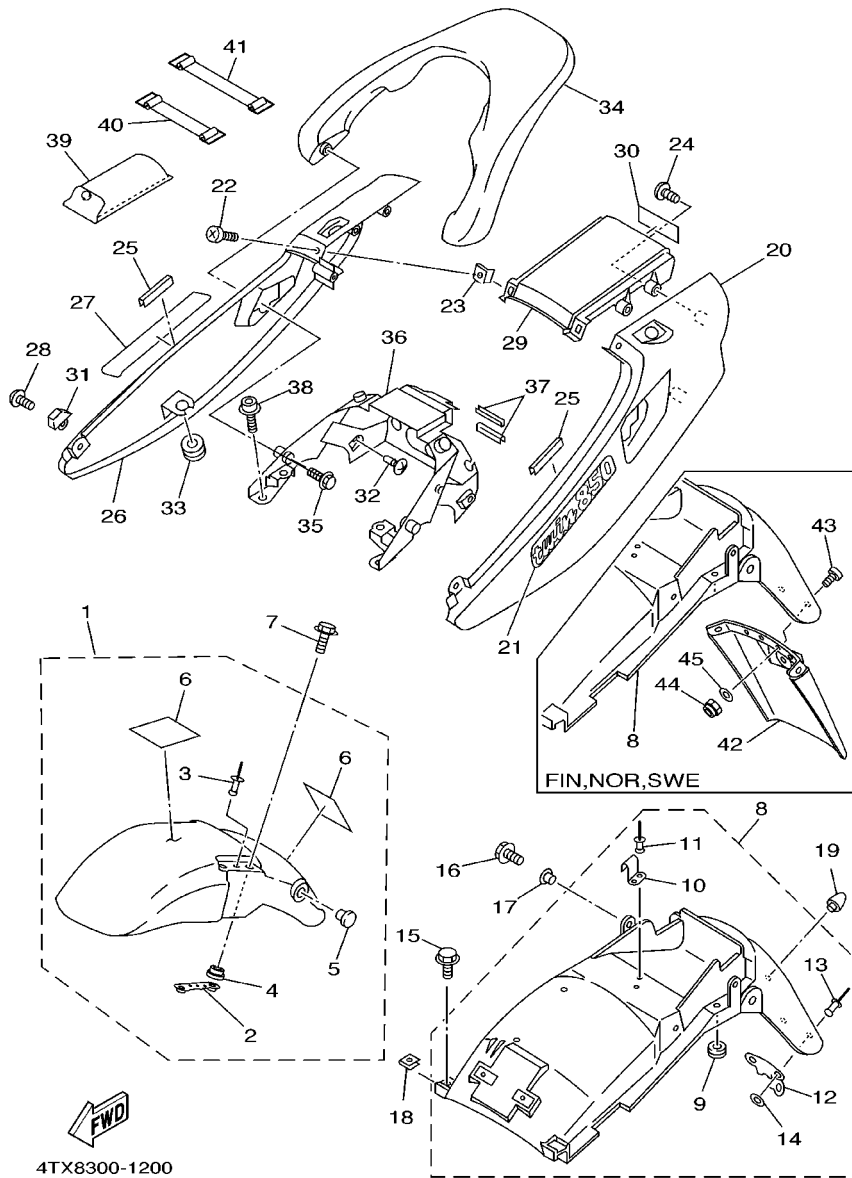

FIG. 20 FENDER

REF. NO.	PART NO.	DESCRIPTION	4TX8	4TX9	REMARKS
1	3VD-Y2151-10-7M	FRONT FENDER COMP.	1		UR MDS FOR BL2
	3VD-Y2151-10-PB	FRONT FENDER COMP.	1	1	UR BMC
	3VD-Y2151-10-PC	FRONT FENDER COMP.	1	1	URPPBM3 FORDPRC3
2	3GM-21512-00	.BRACKET, FENDER	2	2	
3	90267-32071	.RIVET, BLIND	2	2	
4	90387-065T2	.COLLAR	4	4	
5	90338-12192	.PLUG	1	1	
6	3FY-21575-01	.SEAL 1	2	2	
7	90105-06477	BOLT, WASHER BASED	4	4	
8	3VD-Y2161-01	REAR FENDER COMP.	1	1	UR
	3VD-Y2161-G0	REAR FENDER COMP.	1		UR FOR FIN,NOR,SWE
9	90480-10258	.GROMMET	2	2	
10	3VD-21366-00	.HOOK, TOOL BAND	1	1	
11	90267-40073	.RIVET, BLIND	2	2	
12	3HE-85132-01	.BRACKET, REFLECTOR 1	1	1	EXCEPT FOR FIN, NOR,SWE
13	90267-40035	.RIVET, BLIND	2	2	EXCEPT FOR FIN, NOR,SWE
14	90201-04018	.WASHER, PLATE	2	2	EXCEPT FOR FIN, NOR,SWE
15	95027-06010	BOLT, FLANGE	2	2	
16	95027-06020	BOLT, FLANGE	2	2	
17	90387-064J1	COLLAR	2	2	
18	90183-06023	NUT, SPRING	2	2	
19	2MG-21639-00	DAMPER 2	1	1	
20	4TX-2471K-00-4B	COVER, TAIL 1	1	1	UR BL2 FOR BL2,BMC
	4TX-2471K-00-P6	COVER, TAIL 1	1	1	UR DPRC3
21	4TX-21781-A0	EMBLEM 1	1		UR FOR BL2
	4TX-21781-C0	EMBLEM 1	1	1	UR FOR BMC
	4TX-21781-D0	EMBLEM 1	1	1	UR FOR DPRC3

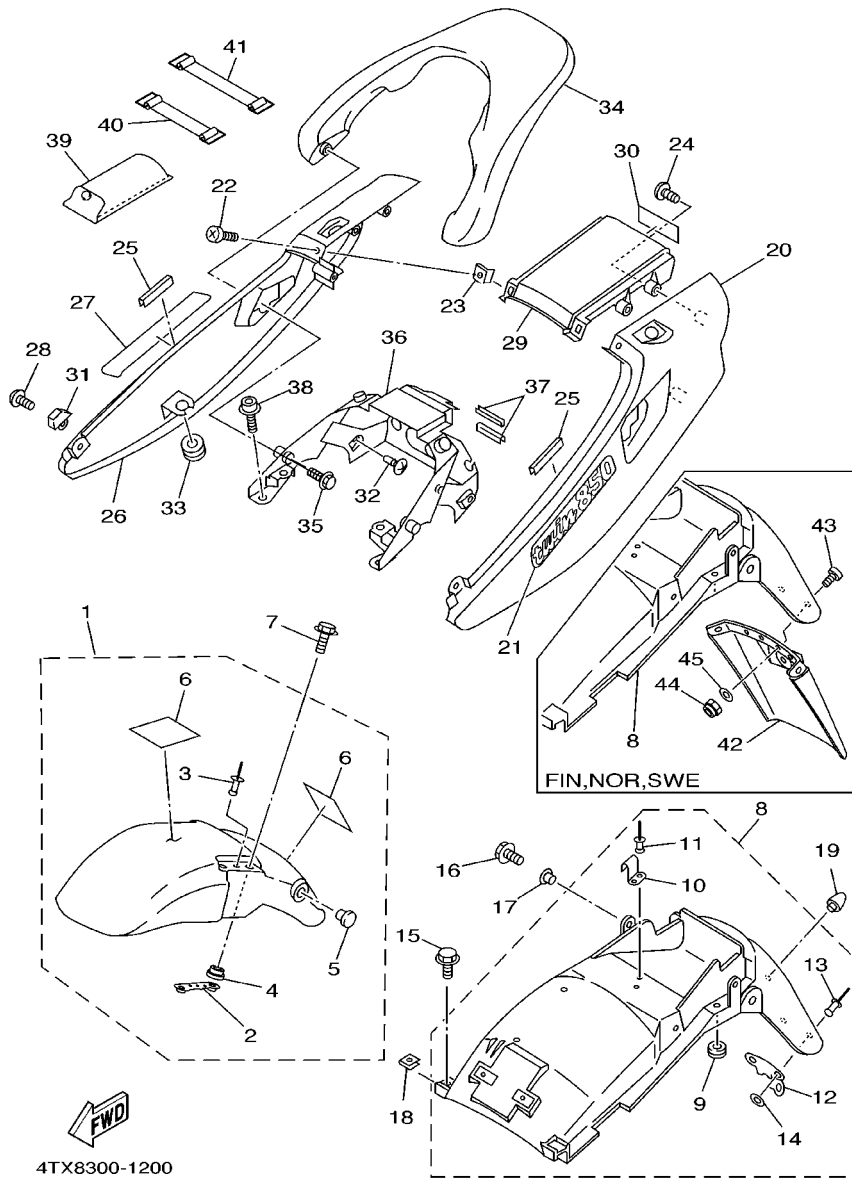
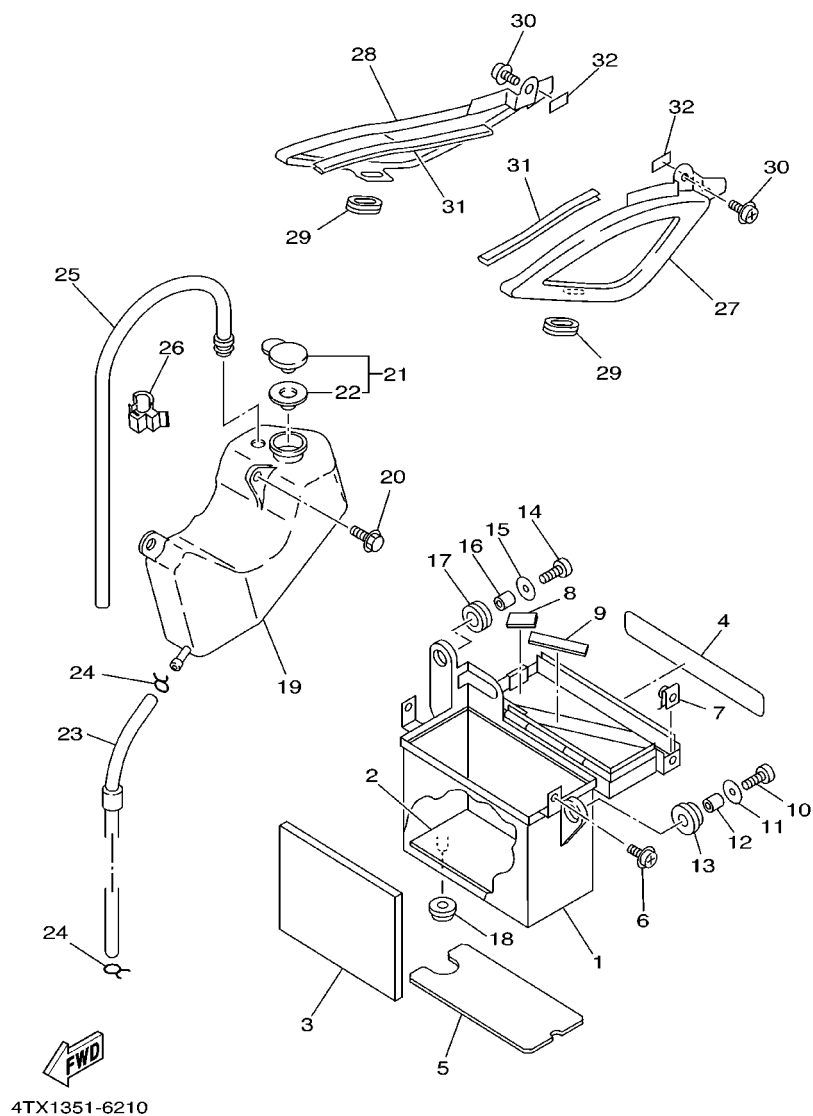

FIG. 20 FENDER

REF. NO.	PART NO.	DESCRIPTION	4TX8	4TX9		REMARKS
22	98907-05010	SCREW, BIND	2	2		
23	90183-05024	NUT, SPRING	2	2		
24	97707-50012	SCREW, TAPPING	4	4		
25	4KB-21268-00	SEAL	2	2		
26	4TX-2472K-00-4B	COVER, TAIL 2	1	1		UR BL2 FOR BL2,BMC
	4TX-2472K-00-P6	COVER, TAIL 2	1	1		UR DPRC3
27	4TX-21781-A0	EMBLEM 1	1			UR FOR BL2
	4TX-21781-C0	EMBLEM 1	1	1		UR FOR BMC
	4TX-21781-D0	EMBLEM 1	1	1		UR FOR DPRC3
28	92017-06012	BOLT, BUTTON HEAD	2	2		
29	4TX-21651-00-4B	COVER, REAR FENDER	1	1		UR BL2 FOR BL2,BMC
	4TX-21651-00-P6	COVER, REAR FENDER	1	1		UR DPRC3
30	99247-00080	EMBLEM, YAMAHA	1			UR FOR BL2
	99246-00080	EMBLEM, YAMAHA	1	1		UR FOR BMC,DPRC3
31	4TX-2161A-00	BRACKET 3	2	2		
32	97707-50012	SCREW, TAPPING	4	4		
33	90480-12550	GROMMET	2	2		
34	3VD-21645-00-4B	STAY, REAR	1	1		UR BL2 FOR BL2,BMC
	3VD-21645-00-PB	STAY, REAR	1	1		UR DPRC3
35	95827-08040	BOLT, FLANGE	4	4		
36	4TX-2117E-00	BRACKET, TAILLIGHT	1	1		
37	46X-21269-00	SEAL	2	2		
38	90109-085E2	BOLT	4	4		
39	4TX-28100-00	TOOL KIT	1	1		
40	116-82131-00	BAND, BATTERY	1	1		
41	133-82131-00	BAND, BATTERY	1	1		
42	3LD-21621-01	FLAP	1			FOR FIN,NOR,SWE

FIG. 21 SIDE COVER



REF. NO.	PART NO.	DESCRIPTION	4TX8	4TX9	REMARKS
1	4TX-2177G-00	BOX, BATTERY	1	1	
2	3Y6-21747-00	DAMPER	1	1	
3	4TX-21732-00	SEAL 1	1	1	
4	4TX-21735-00	SEAL 2	1	1	
5	4TX-2173M-00	SEAL 3	1	1	
6	90159-06093	SCREW, WITH WASHER	2	2	
7	90183-06053	NUT, SPRING	2	2	
8	51Y-21639-00	DAMPER 2	1	1	
9	50M-21638-00	DAMPER 1	1	1	
10	91317-06025	BOLT	1	1	
11	90201-06071	WASHER, PLATE	1	1	
12	90560-07007	SPACER	1	1	
13	90480-16404	GROMMET	1	1	
14	91317-06025	BOLT	1	1	
15	90201-06071	WASHER, PLATE	1	1	
16	90387-07674	COLLAR	1	1	
17	90480-16233	GROMMET	1	1	
18	90480-13369	GROMMET	1	1	
19	3VD-21871-00	TANK, RECOVERY	1	1	
20	90119-06056	BOLT, WITH WASHER	2	2	
21	1AA-21815-00	CAP	1	1	
22	1AA-21874-00	.GASKET	1	1	
23	90445-086J6	HOSE (L1040)	1	1	
24	90467-08075	CLIP	2	2	
25	3VD-21816-00	PIPE 1	1	1	
26	90464-10190	CLAMP	1	1	
27	4TX-21711-00	COVER, SIDE 1	1	1	

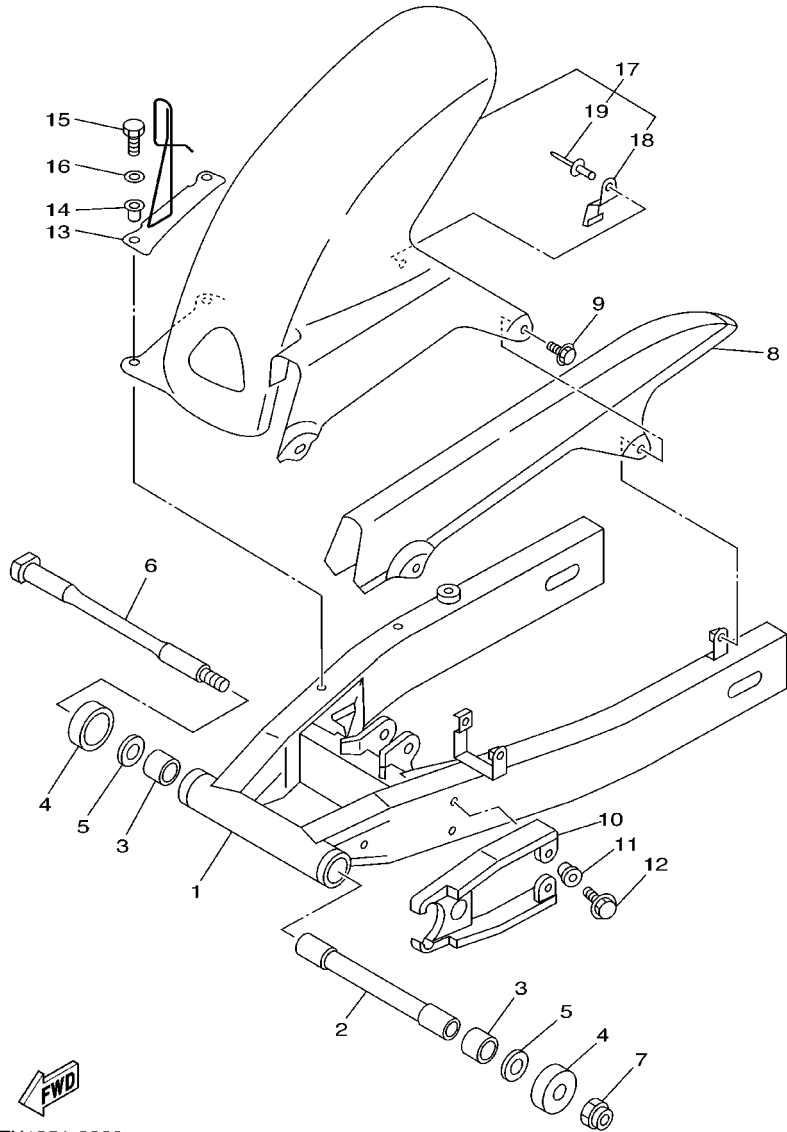

4TX1351-6220

FIG. 22 REAR ARM

REF. NO.	PART NO.	DESCRIPTION	4TX8	4TX9	REMARKS
1	4TX-22110-00	REAR ARM COMP.	1	1	
2	33M-22184-00	BUSH	1	1	
3	93320-32403	BEARING	2	2	
4	4X7-22129-00	COVER, THRUST 2	2	2	
5	90201-161J3	WASHER, PLATE	2	2	
6	46X-22141-00	SHAFT, PIVOT	1	1	
7	90185-14112	NUT, SELF-LOCKING	1	1	
8	3VD-22311-00	CASE, CHAIN	1	1	
9	90119-06044	BOLT, WITH WASHER	2	2	
10	3VD-22151-00	SEAL, GUARD	1	1	
11	90387-06681	COLLAR	3	3	
12	90119-06108	BOLT, WITH WASHER	3	3	
13	3VD-25875-01	HOLDER, BRAKE HOSE 1	1	1	
14	90387-064J1	COLLAR	2	2	
15	97007-06025	BOLT	2	2	
16	92907-06600	WASHER, PLATE	2	2	
17	3VD-W2165-00	FENDER COMP, REAR TIRE	1	1	
18	3VD-2164F-00	.STAY 1	1	1	
19	90267-40105	.RIVET, BLIND	1	1	

FIG. 24 STEERING

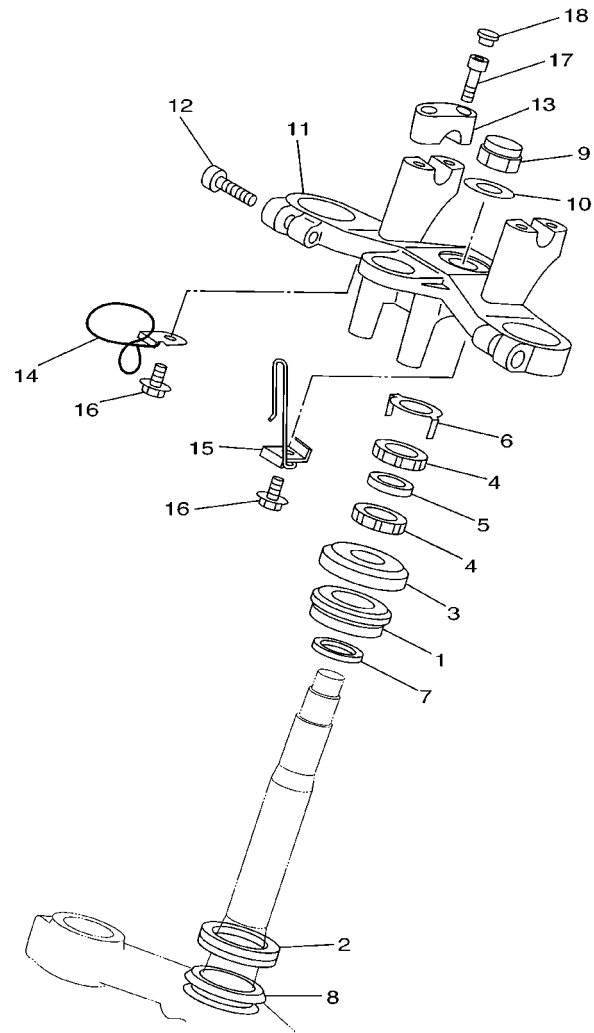

FWD
4TX4351-9240

REF. NO.	PART NO.	DESCRIPTION	4TX8	4TX9		REMARKS
1	93399-99931	BEARING	1	1		
2	93399-99932	BEARING	1	1		
3	1W1-23416-00	COVER, BALL RACE 2	1	1		
4	90179-25033	NUT	2	2		
5	90202-26142	WASHER, PLATE	1	1		
6	26H-23418-01	WASHER, SPECIAL	1	1		
7	90202-24190	WASHER, PLATE	1	1		
8	3FV-23462-00	SEAL, STEERING	1	1		
9	90176-22081	NUT, CROWN	1	1		
10	90201-220T0	WASHER, PLATE	1	1		
11	4TX-23435-00	CROWN, HANDLE	1	1		
12	91314-08030	BOLT	2	2		
13	4H7-23441-00-P0	HOLDER, HANDLE UPPER	2	2		LGM1
14	4TX-23389-00	GUIDE, CABLE	1	1		
15	4TX-2331E-00	GUIDE, CABLE	1	1		
16	90105-06556	BOLT, WASHER BASED	2	2		
17	91314-08030	BOLT	4	4		
18	90338-08163	PLUG	4	4		

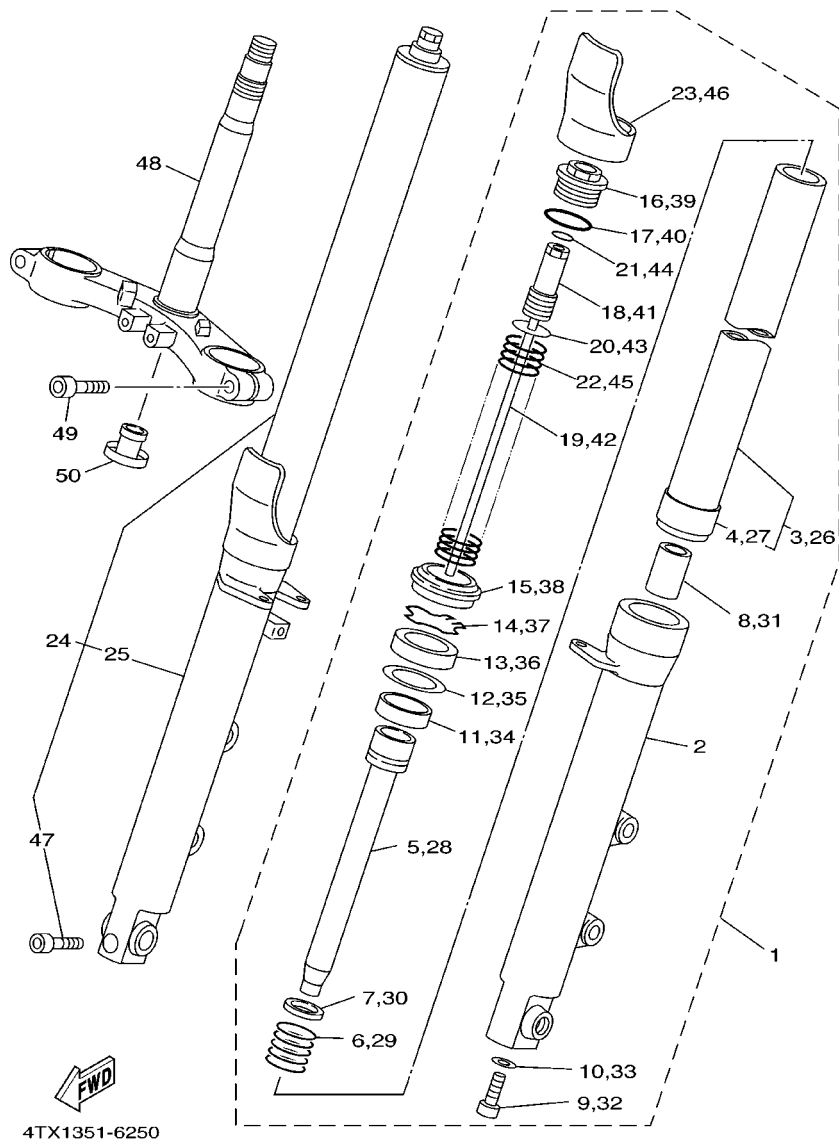

FIG. 25 FRONT FORK

REF. NO.	PART NO.	DESCRIPTION	4TX8	4TX9				REMARKS
1	4TX-23102-01	FRONT FORK ASSY (L.H)	1	1				
2	4TX-23126-01	.TUBE, OUTER (LEFT)	1	1				
3	4TX-23110-00	.INNER TUBE COMP.1	1	1				
4	4TX-23135-A0	..METAL, SLIDE 2	1	1				
5	4TX-23170-00	.CYLINDER COMP., FRONT FORK	1	1				
6	4TX-23151-00	.SPRING, REBOUND	1	1				
7	4TX-23157-00	.RING, PISTON	1	1				
8	4TX-23173-00	.SPINDLE, TAPER	1	1				
9	91317-10025	.BOLT	1	1				
10	90430-10171	.GASKET	1	1				
11	4TX-23125-A0	.METAL, SLIDE 1	1	1				
12	4TX-23115-00	.GUIDE, COVER UPPER	1	1				
13	4TX-23145-00	.OIL SEAL	1	1				
14	4TX-23156-00	.CLIP, OIL SEAL	1	1				
15	4TX-23144-00	.SEAL, DUST	1	1				
16	4TX-2311H-00	.FORK, BOLT	1	1				
17	93210-34504	.O-RING	1	1				
18	4TX-2311G-00	.BOLT, SPRINGADJUST	1	1				
19	4TX-2319K-00	.PLUNGER KIT	1	1				
20	4TX-2331L-00	.SEAT, SPRING UPPER	1	1				
21	93210-18N01	.O-RING	1	1				
22	4TX-23141-00	.SPRING, FRONT FORK	1	1				
23	4TX-2331G-00	.COVER	1	1				
24	4TX-23103-01	FRONT FORK ASSY (R.H)	1	1				
25	4TX-23136-01	.TUBE, OUTER (RIGHT)	1	1				
26	4TX-23110-00	.INNER TUBE COMP.1	1	1				
27	4TX-23135-A0	..METAL, SLIDE 2	1	1				

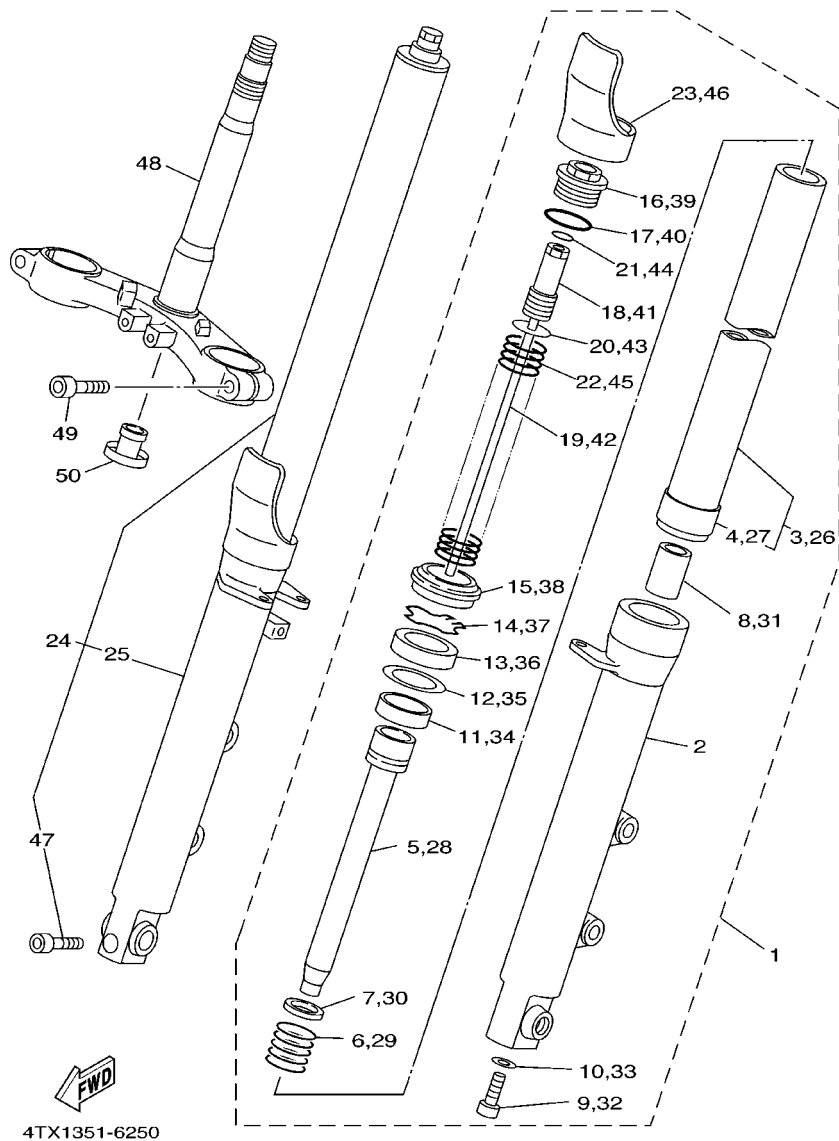
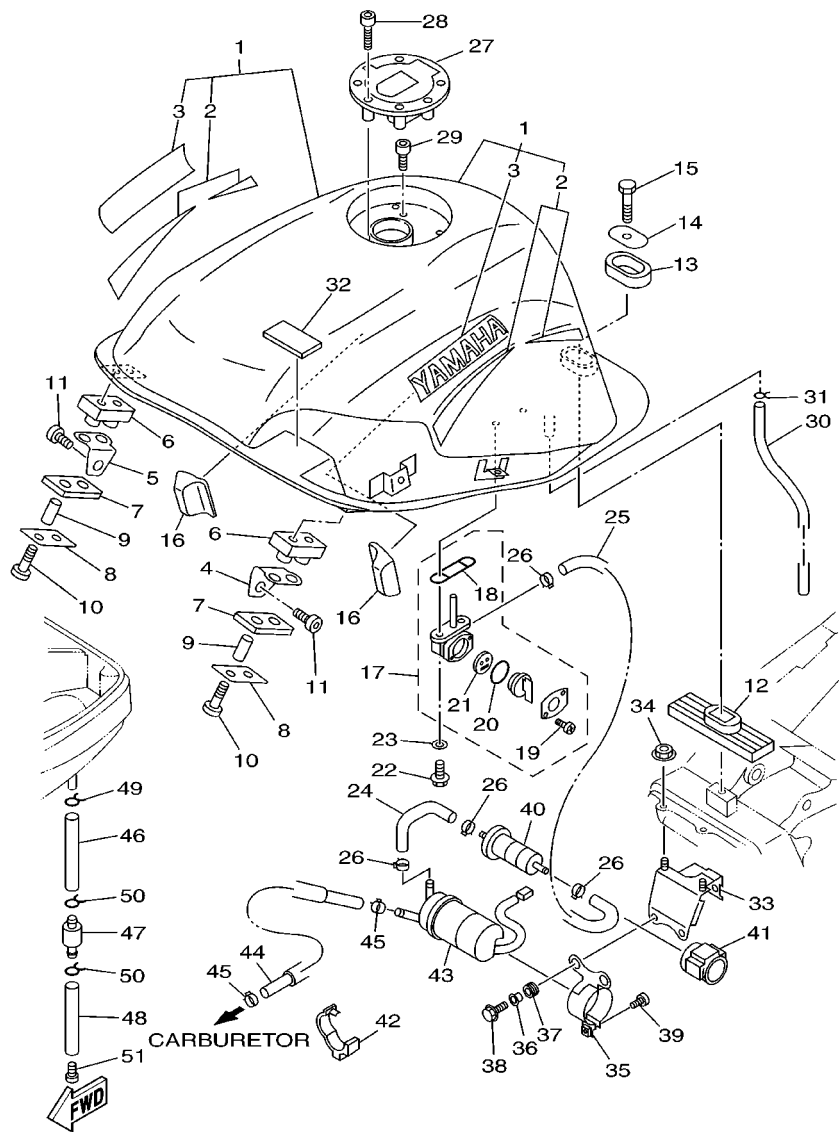

FIG. 25 FRONT FORK

REF. NO.	PART NO.	DESCRIPTION	4TX8	4TX9				REMARKS
28	4TX-23170-00	.CYLINDER COMP., FRONT FORK	1	1				
29	4TX-23151-00	.SPRING, REBOUND	1	1				
30	4TX-23157-00	.RING, PISTON	1	1				
31	4TX-23173-00	.SPINDLE, TAPER	1	1				
32	91317-10025	.BOLT	1	1				
33	90430-10171	.GASKET	1	1				
34	4TX-23125-A0	.METAL, SLIDE 1	1	1				
35	4TX-23115-00	.GUIDE, COVER UPPER	1	1				
36	4TX-23145-00	.OIL SEAL	1	1				
37	4TX-23156-00	.CLIP, OIL SEAL	1	1				
38	4TX-23144-00	.SEAL, DUST	1	1				
39	4TX-2311H-00	.FORK, BOLT	1	1				
40	93210-34504	.O-RING	1	1				
41	4TX-2311G-00	.BOLT, SPRINGADJUST	1	1				
42	4TX-2319K-00	.PLUNGER KIT	1	1				
43	4TX-2331L-00	.SEAT, SPRING UPPER	1	1				
44	93210-18N01	.O-RING	1	1				
45	4TX-23141-00	.SPRING, FRONT FORK	1	1				
46	4TX-2331G-00	.COVER	1	1				
47	91317-08040	.BOLT	1	1				
48	4TX-23340-00	UNDER BRACKET COMP.	1	1				
49	91317-10030	BOLT	2	2				
50	4KM-23123-01	COVER, LOWER 1	1	1				

FIG. 26 FUEL TANK



4TX4351-9261

REF. NO.	PART NO.	DESCRIPTION	4TX8	4TX9	REMARKS
1	4TX-Y2410-50-04	FUEL TANK COMP.	1		UR BL2
	4TX-Y2410-50-06	FUEL TANK COMP.	1	1	UR BMC
	4TX-Y2410-50-07	FUEL TANK COMP.	1	1	UR DPRC3
2	4TX-24240-A0	.GRAPHIC SET	1		UR FOR BL2
	4TX-24240-80	.GRAPHIC SET	1	1	UR FOR BMC
	4TX-24240-C0	.GRAPHIC SET	1	1	UR FOR DPRC3
3	99227-00140	.EMBLEM, YAMAHA	2		UR FOR BL2
	99226-00140	.EMBLEM, YAMAHA	2	2	UR FOR BMC,DPRC3
4	4TX-24191-00	BRACKET, FUEL TANK 1	1	1	
5	4TX-24192-00	BRACKET, FUEL TANK 2	1	1	
6	3VD-24181-00	DAMPER, LOCATING 1	2	2	
7	47X-24183-00	DAMPER, LOCATING 3	2	2	
8	47X-24186-00	WASHER, SPECIAL	2	2	
9	90387-06605	COLLAR	4	4	
10	92017-06035	BOLT, BUTTON HEAD	4	4	
11	90109-086A0	BOLT	2	2	
12	2GH-24184-00	DAMPER, LOCATING 4	1	1	
13	3Y6-24183-00	DAMPER, LOCATING 3	1	1	
14	12R-24186-00	WASHER, SPECIAL	1	1	
15	97007-08030	BOLT	1	1	
16	4TX-2411K-00	STOPPER	2	2	
17	4KM-24500-10	FUEL COCK ASSY 1	1	1	
18	4X8-24512-00	.O-RING	1	1	
19	98507-03008	.SCREW, PAN HEAD	2	2	
20	3AJ-24534-00	.SEAL, COCK	1	1	
21	3AJ-24523-00	.VALVE PACKING	1	1	
22	90149-06011	SCREW	2	2	

FIG. 26 FUEL TANK

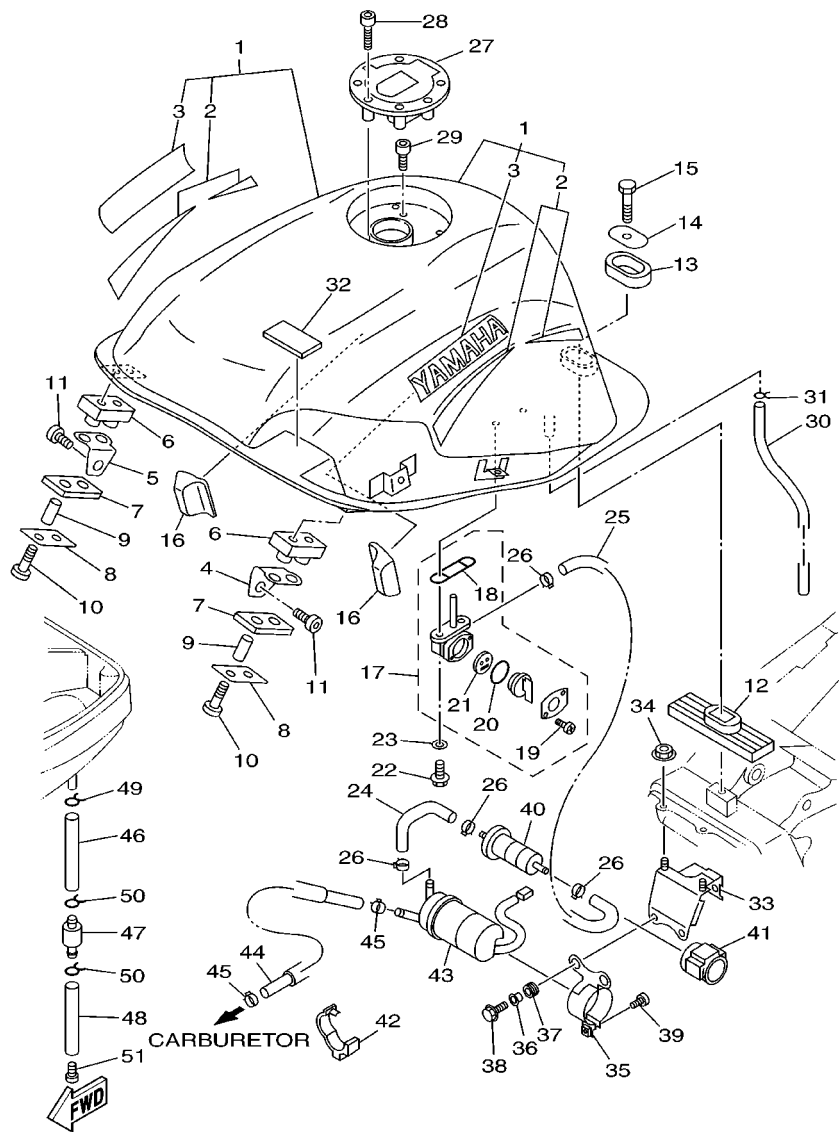

4TX4351-9261

REF. NO.	PART NO.	DESCRIPTION	4TX8	4TX9				REMARKS
23	90202-05193	WASHER, PLATE	2	2				
24	4TX-24311-40	PIPE, FUEL 1	1	1				
25	4TX-24315-40	PIPE 5	1	1				
26	90467-12053	CLIP	4	4				
27	4FM-24602-10	CAP ASSY	1	1				
28	90110-05112	BOLT, HEXAGON SOCKET HEAD	3	3				
29	91317-05010	BOLT	1	1				
30	90445-106J2	HOSE (L650)	1	1				
31	90467-09006	CLIP	1	1				
32	30X-2139X-00	DAMPER	2	2				
33	4TX-2452E-40	STAY	1	1				
34	95607-06200	NUT, SELF U-FLANGE	2	2				
35	3CV-24491-10	BRACKET, FUEL PUMP	1	1				
36	90387-062L2	COLLAR	2	2				
37	90480-13163	GROMMET	2	2				
38	95807-06016	BOLT, FLANGE	2	2				
39	98507-05010	SCREW, PAN HEAD	1	1				
40	1FK-24560-00	FILTER ASSY	1	1				
41	1FK-24566-00	BRACKET, FILTER	1	1				
42	90464-15192	CLAMP	1	1				
43	4TX-13907-40	FUEL PUMP COMP.	1	1				
44	4TX-14294-40	HOSE	1	1				
45	90467-12053	CLIP	2	2				
46	90445-11153	HOSE (L460)	1	1				
47	4X7-2149Y-00	FILTER ASSY	1	1				
48	90445-112E1	HOSE (L370)	1	1				
49	90467-11106	CLIP	1	1				

FIG. 27 SEAT

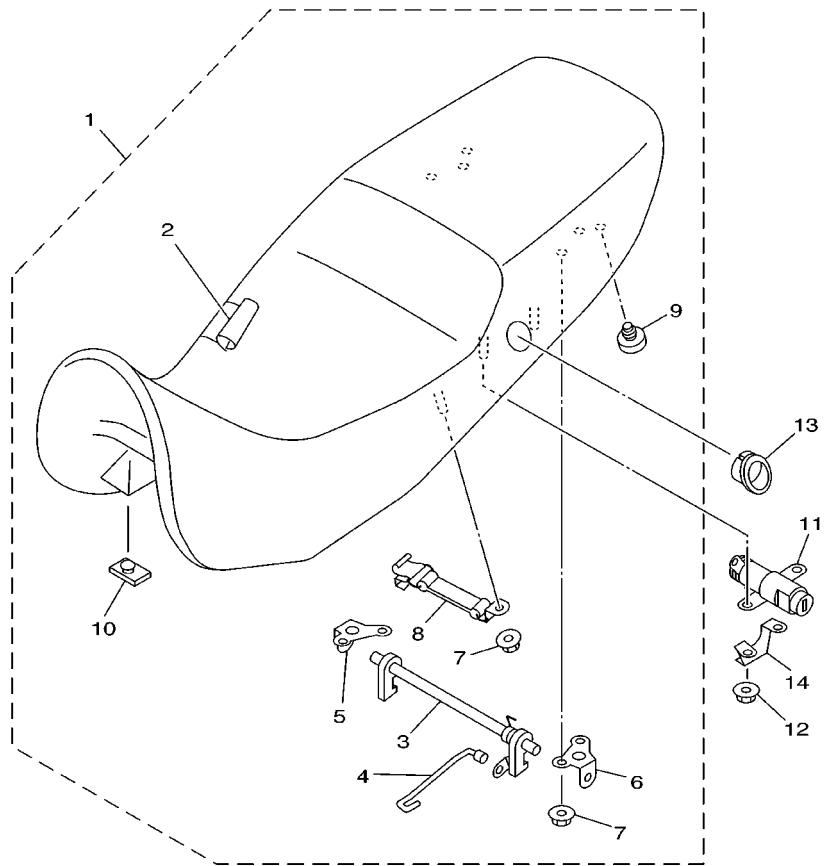

REF. NO.	PART NO.	DESCRIPTION	4TX8	4TX9				REMARKS
1	4TX-24730-01	DOUBLE SEAT ASSY	1	1				
2	4TX-24731-00	.COVER, SEAT	1	1				
3	4TX-24776-01	.LEVER, SEAT	1	1				
4	4TX-2478F-00	.ROD, CONNECTING	1	1				
5	4TX-24728-00	.BRACKET, SEAT	1	1				
6	4TX-24718-00	.BRACKET, SEAT	1	1				
7	90179-06635	.NUT	6	6				
8	4TX-21376-00	.BAND, TOOL	2	2				
9	22W-24741-00	.PAD, SEAT	2	2				
10	509-24724-00	.DAMPER, SEAT	2	2				
11	4BH-24705-00	SEAT LOCK ASSY	1	1				
12	95707-05500	NUT, FLANGE	2	2				
13	47X-24796-00	COVER	1	1				
14	4TX-24748-00	BRACKET, SEAT	1	1				



4TX1351-6270

FIG. 28 FRONT WHEEL

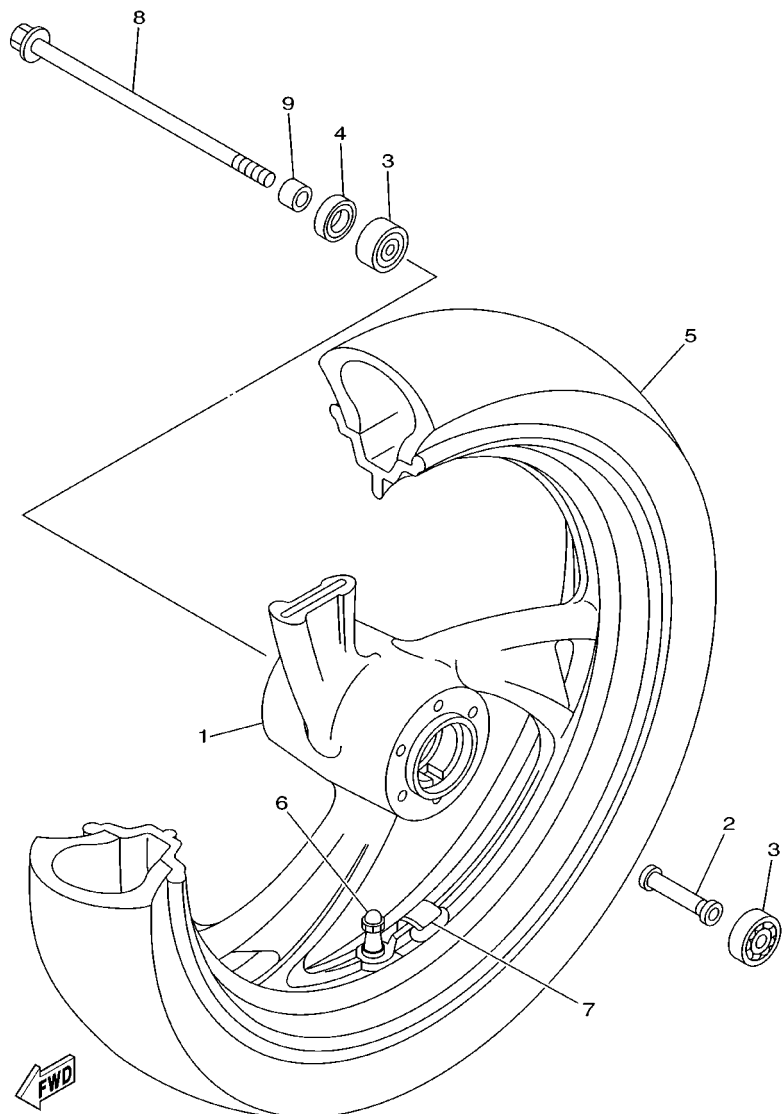

4TX4351-9280

REF. NO.	PART NO.	DESCRIPTION	4TX8	4TX9	REMARKS
1	3VD-25168-00-7B	CAST WHEEL, FRONT	1	1	BIB2
2	90560-17233	SPACER	1	1	
3	93306-30319	BEARING	2	2	
4	93102-28022	OIL SEAL	1	1	
5	94111-1810C	TIRE (110/80ZR18 BATTLAX BT-54F)	1	1	UR BRIDGESTONE
	*	TIRE (110/80ZR18 MACADAM 90X)	1		UR LM MICHELIN FOR ITALY
6	93900-00030	VALVE, RIM	1	1	
7	29L-25398-00	BALANCER, WHEEL (10G)	1	1	UR
	29L-25398-10	BALANCER, WHEEL (20G)	1	1	UR
	29L-25398-20	BALANCER, WHEEL (30G)	1	1	UR
8	3GM-25181-03	AXLE, WHEEL	1	1	
9	90387-177R1	COLLAR	1	1	

FIG. 29 FRONT BRAKE CALIPER

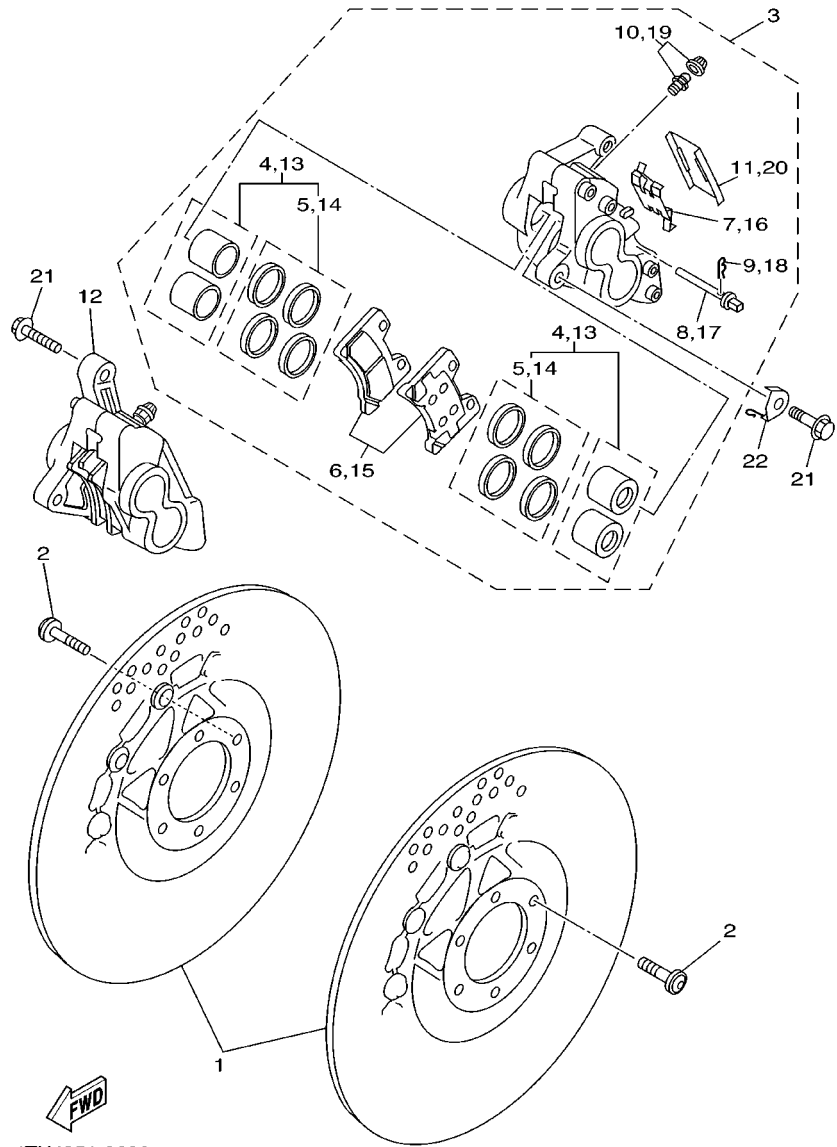

4TX4351-9290

REF. NO.	PART NO.	DESCRIPTION	4TX8	4TX9	REMARKS
1	4HM-2581T-01	DISC BRAKE ASSY	2	2	
2	90109-083G4	BOLT	12	12	
3	3HE-2580T-70	CALIPER ASSY (LEFT)	1	1	
4	3HE-W0057-50	.PISTON ASSY, CALIPER	2	2	
5	3HE-W0047-50	..CALIPER SEAL KIT	2	2	
6	3GM-W0045-03	.BRAKE PAD KIT	1	1	
7	3GM-25919-00	.SUPPORT, PAD	1	1	
8	3HE-25924-00	.PIN, PAD	2	2	
9	3GM-25925-00	.CLIP	2	2	
10	1J3-W0048-00	.BLEED SCREW KIT	1	1	
11	1KT-25836-00	.COVER, DUST	1	1	
12	3HE-2580U-70	CALIPER ASSY (RIGHT)	1	1	
13	3HE-W0057-50	.PISTON ASSY, CALIPER	2	2	
14	3HE-W0047-50	..CALIPER SEAL KIT	2	2	
15	3GM-W0045-03	.BRAKE PAD KIT	1	1	
16	3GM-25919-00	.SUPPORT, PAD	1	1	
17	3HE-25924-00	.PIN, PAD	2	2	
18	3GM-25925-00	.CLIP	2	2	
19	1J3-W0048-00	.BLEED SCREW KIT	1	1	
20	1KT-25836-00	.COVER, DUST	1	1	
21	90105-10638	BOLT, WASHER BASED	4	4	
22	4YR-23317-00	HOLDER, CABLE	1	1	

FIG. 30 REAR WHEEL

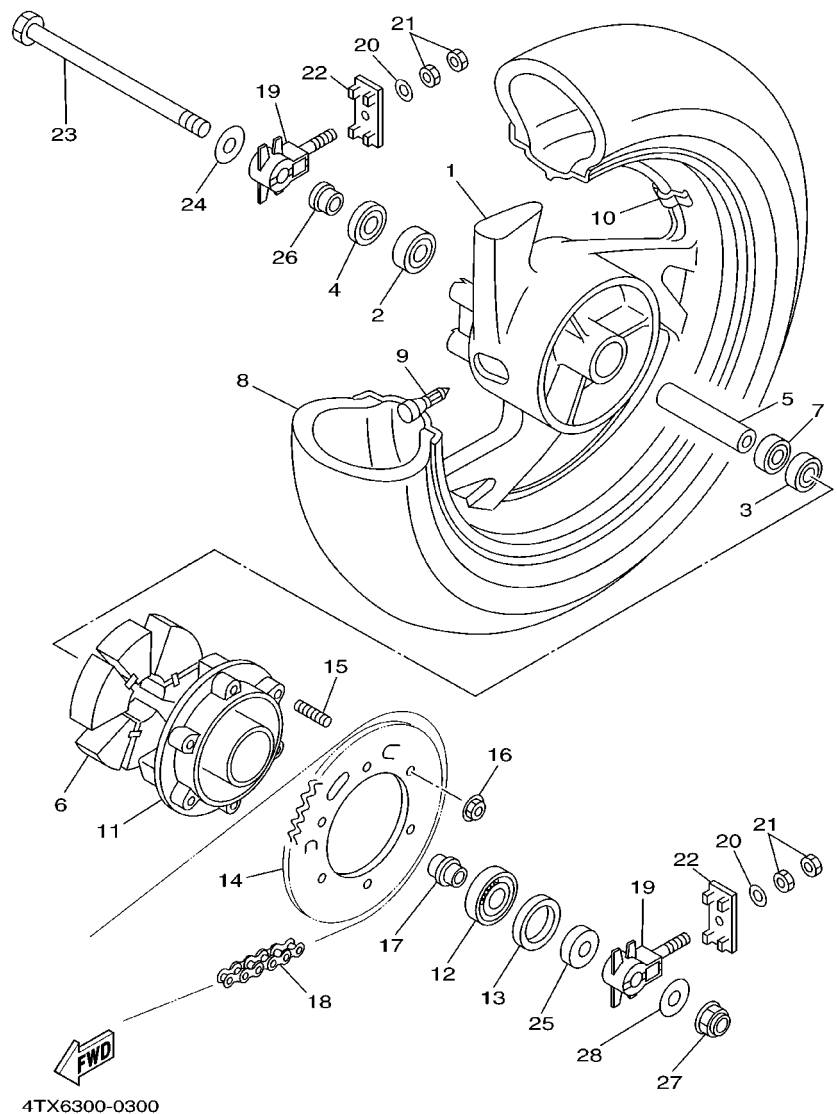

4TX6300-0300

REF. NO.	PART NO.	DESCRIPTION	4TX8	4TX9	REMARKS
1	3VD-25338-00-7B	CAST WHEEL, REAR	1	1	BIB2
2	93306-30320	BEARING	1	1	
3	93306-20314	BEARING (B6203)	1	1	
4	93102-25044	OIL SEAL	1	1	
5	90387-173M5	COLLAR	1	1	

6	4TX-25364-40	DAMPER	3	3	
7	93306-20314	BEARING (B6203)	1	1	
8	94115-1710D	TIRE (150/70ZR17 BATTLAX BT-54F)	1	1	UR BRIDGESTONE
	*	TIRE (150/70ZR17 MACADAM 90X)	1		UR LM MICHELIN FOR ITALY
9	93900-00030	VALVE, RIM	1	1	

10	29L-25398-00	BALANCER, WHEEL (10G)	1	1	UR
	29L-25398-10	BALANCER, WHEEL (20G)	1	1	UR
	29L-25398-20	BALANCER, WHEEL (30G)	1	1	UR
11	1AE-25366-00	CLUTCH, HUB	1	1	
12	93306-37207	BEARING	1	1	

13	93105-42024	OIL SEAL	1	1	
14	4TX-25443-40	SPROCKET, DRIVEN (43T)	1	1	
15	90116-10485	BOLT, STUD	6	6	
16	95607-10200	NUT, SELF-LOCKING	6	6	
17	90387-177K0	COLLAR	1	1	

18	94581-46114	CHAIN (D.I.D.525HV-114LE)	1	1	
19	4BP-25388-00	PULLER, CHAIN 1	2	2	
20	92907-08200	WASHER	2	2	
21	95307-08600	NUT	4	4	
22	3HE-22174-00	END 1	2	2	

23	3AJ-25381-01	AXLE, WHEEL	1	1	
24	90201-170T3	WASHER, PLATE	1	1	

FIG. 31 REAR BRAKE CALIPER

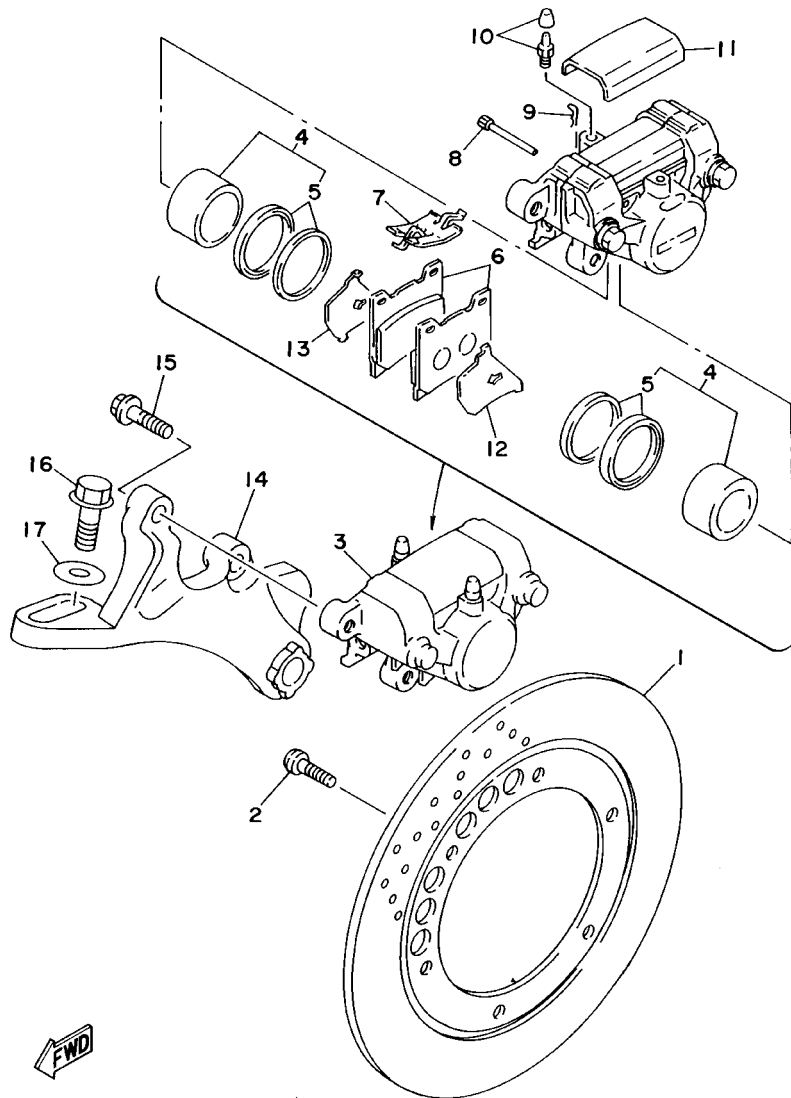

3VDI351-1310

REF. NO.	PART NO.	DESCRIPTION	4TX8	4TX9	REMARKS
1	4HM-2582W-00	DISC, REAR BRAKE 2	1	1	
2	90109-083G4	BOLT	6	6	
3	4TX-2580W-00	CALIPER ASSY, REAR 2	1	1	
4	31A-W0057-00	.PISTON ASSY, CALIPER	1	1	
5	31A-W0047-00	..CALIPER SEAL KIT	1	1	
6	4SV-W0045-50	.BRAKE PAD KIT	1	1	
7	29L-25919-00	.SUPPORT, PAD	1	1	
8	3HE-25924-00	.PIN, PAD	2	2	
9	3GM-25925-00	.CLIP	2	2	
10	1J3-W0048-00	.BLEED SCREW KIT	2	2	
11	42H-25836-00	.COVER, DUST	1	1	
12	1FK-25827-00	.SHIM, CALIPER	1	1	
13	1FK-25828-00	.SHIM, CALIPER	1	1	
14	3VD-25819-00	BRACKET, CALIPER	1	1	
15	90105-10638	BOLT, WASHER BASED	2	2	
16	95827-10030	BOLT, FLANGE	1	1	
17	90201-10437	WASHER, PLATE	1	1	

FIG. 32 STEERING HANDLE. CABLE

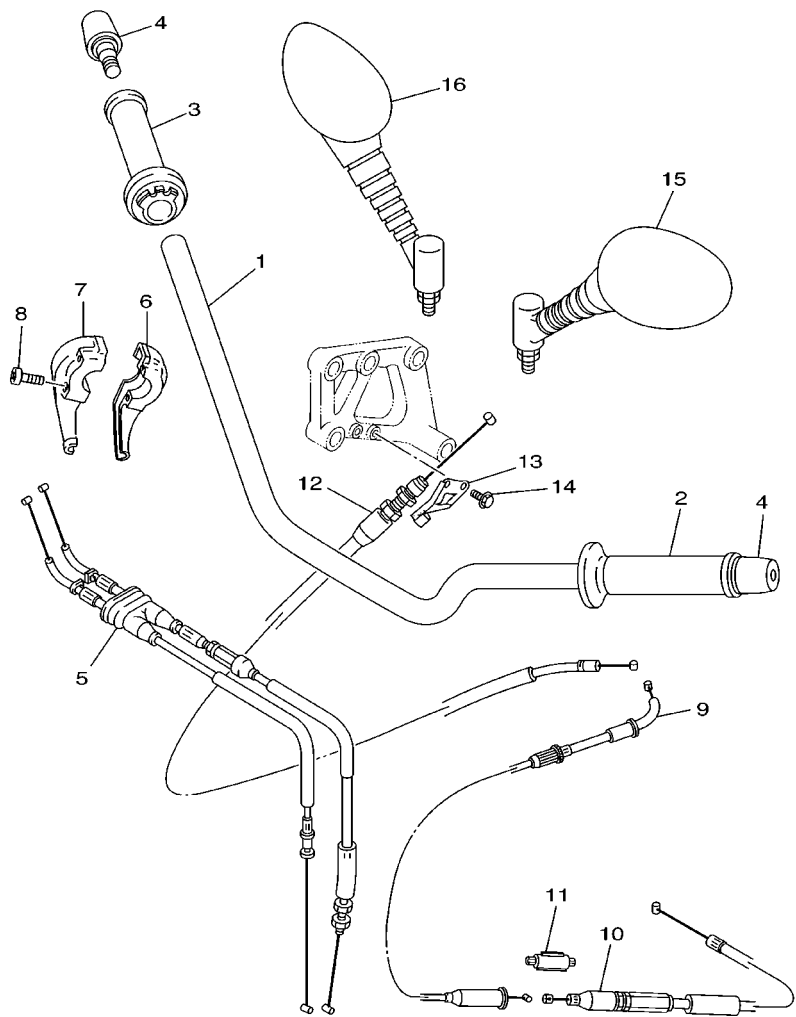

REF. NO.	PART NO.	DESCRIPTION	4TX8	4TX9			REMARKS
1	3VD-26111-20	HANDLEBAR	1	1			
2	1KG-26241-00	GRIP (LEFT)	1	1			
3	3FH-26240-00	GRIP ASSY	1	1			
4	51J-26246-01	END, GRIP	2	2			
5	4TX-26302-40	THROTTLE CABLE ASSY	1	1			
6	3XW-26281-01	CAP, GRIP UPPER	1	1			
7	3XW-26282-01	CAP, GRIP LOWER	1	1			
8	98507-05035	SCREW, PAN HEAD	2	2			
9	4TX-26331-40	CABLE, STARTER 1	1	1			
10	4TX-26334-40	CABLE, STARTER 2	1	1			
11	3VP-26261-00	CONNECTOR, CABLE	1	1			
12	4TX-26335-01	CABLE, CLUTCH	1	1			
13	4TX-26292-00	STAY	1	1			
14	95027-06012	BOLT, FLANGE	2	2			
15	4TX-26280-41	REAR VIEW MIRROR ASSY(LEFT)	1	1			
16	4TX-26290-41	REAR VIEW MIRROR ASSY(RIGHT)	1	1			

4TX4351-9320

FIG. 33 FRONT MASTER CYLINDER

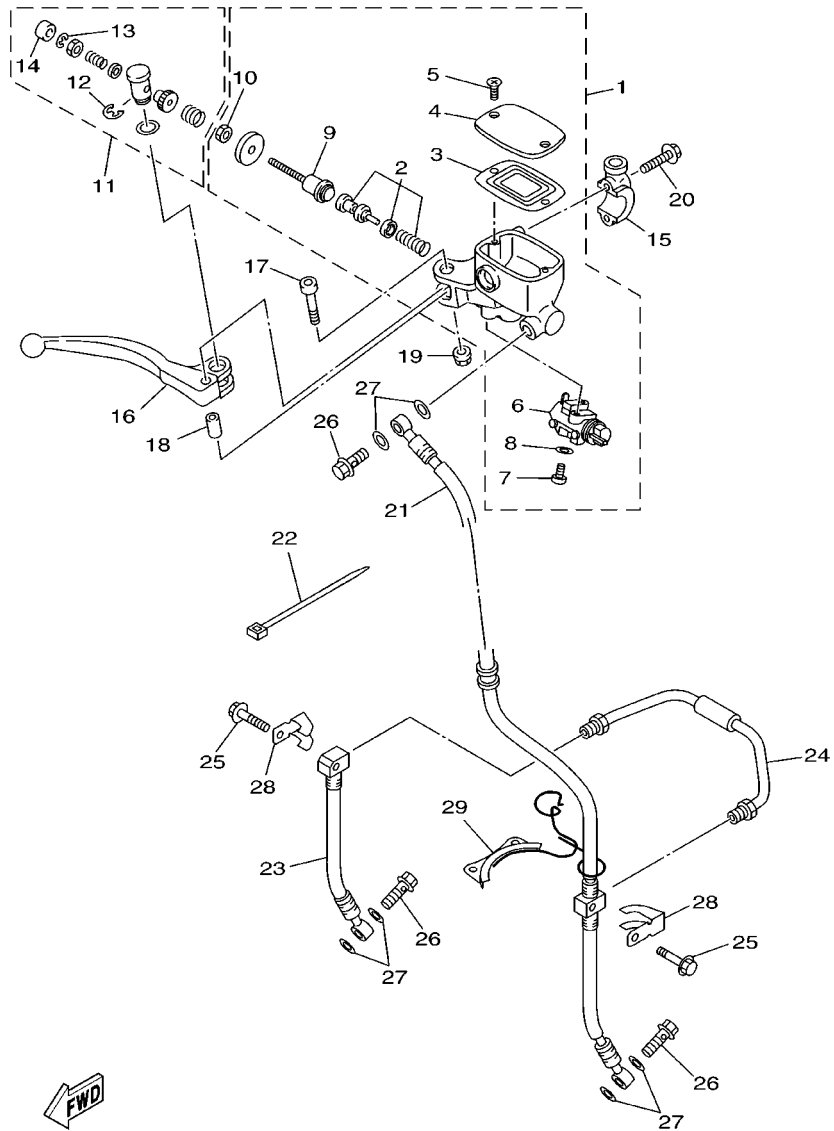

4TX4351-9331

REF. NO.	PART NO.	DESCRIPTION	4TX8	4TX9			REMARKS
1	4TX-W2587-00	MASTER CYLINDER SUB ASSY	1	1			
2	4BH-W0041-00	.CYLINDER KIT, MASTER	1	1			
3	3YX-25854-00	.DIAPHRAGM, RESERVOIR	1	1			
4	4TX-25852-00	.CAP, RESERVOIR	1	1			
5	98706-04012	.SCREW, FLAT HEAD	2	2			
6	4BH-83980-00	.FRONT STOP SWITCH ASSY	1	1			
7	98506-04014	.SCREW, PAN HEAD	2	2			
8	92906-04600	.WASHER, PLATE	2	2			
9	3YX-25880-00	.PUSH ROD COMP.	1	1			
10	95301-06600	.NUT	1	1			
11	3YX-W0091-02	SCREW KIT, MASTERCYLINDER	1	1			
12	3YX-25866-00	.CIRCLIP	1	1			
13	3YX-25866-10	.CIRCLIP	1	1			
14	3YX-2583H-00	.BOOT	1	1			
15	3YX-25867-00	BRACKET, MASTER CYLINDER	1	1			
16	3YX-83922-00	LEVER 2	1	1			
17	3YX-2589F-00	BOLT, LEVER	1	1			
18	3YX-25838-00	SLEEVE, CALIPER	1	1			
19	95606-06100	NUT, U	1	1			
20	95026-06030	BOLT, FLANGE	2	2			
21	4TX-25872-40	HOSE, BRAKE 1	1	1			
22	1UA-82591-00	BAND	2	2			
23	4TX-25874-00	HOSE, BRAKE	1	1			
24	4TX-25871-00	PIPE, BRAKE	1	1			
25	95024-06025	BOLT, FLANGE	2	2			
26	90401-10159	BOLT, UNION	3	3			
27	90201-10118	WASHER, PLATE	6	6			

FIG. 34 STAND, FOOTREST

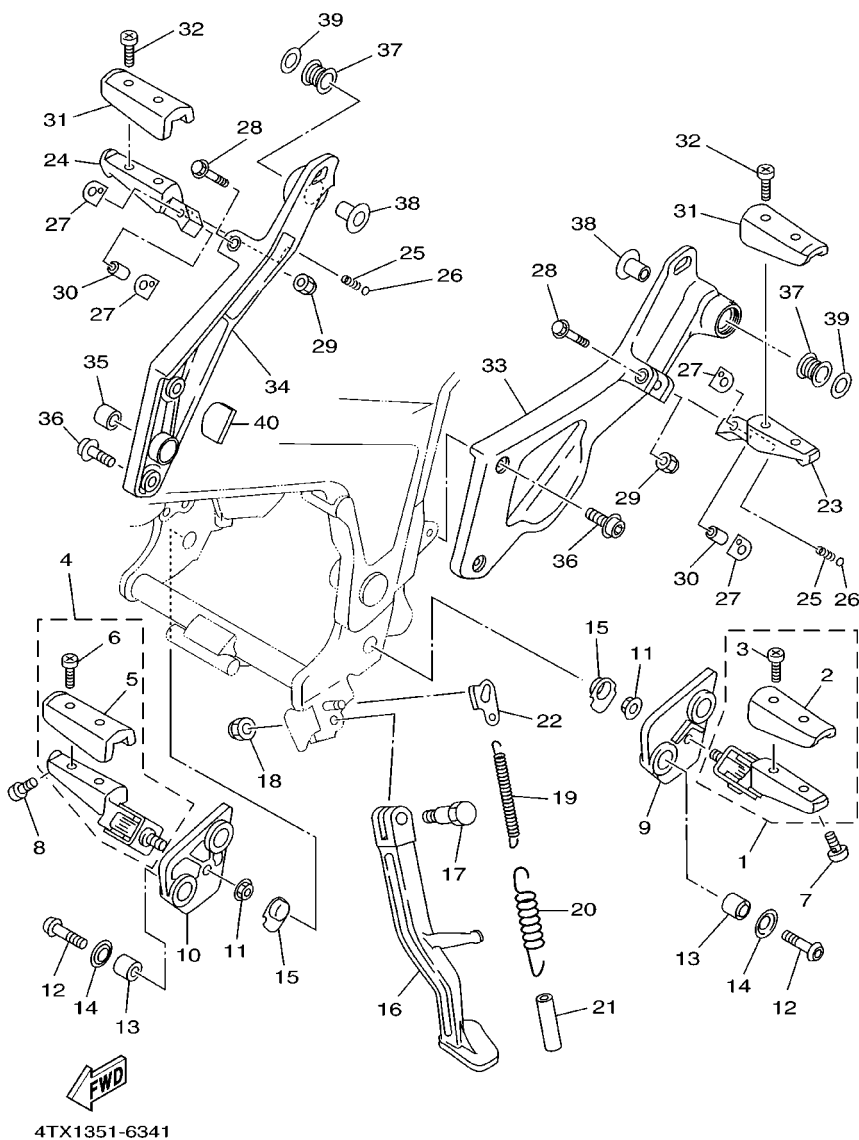

4TX1351-6341

REF. NO.	PART NO.	DESCRIPTION	4TX8	4TX9	REMARKS
1	1UA-27410-00	FRONT FOOTREST ASSY (LEFT)	1	1	
2	46X-27413-00	.COVER, FOOTREST	1	1	
3	90157-05079	.SCREW, PAN HEAD	2	2	
4	1UA-27420-00	FRONT FOOTREST ASSY (RIGHT)	1	1	
5	46X-27413-00	.COVER, FOOTREST	1	1	
6	90157-05079	.SCREW, PAN HEAD	2	2	
7	90109-083E2	BOLT	1	1	
8	90109-083E2	BOLT	1	1	
9	3VD-27442-11	BRACKET 2	1	1	
10	3VD-27443-11	BRACKET 3	1	1	
11	90179-10247	NUT	2	2	
12	90110-08071	BOLT, HEXAGON SOCKET HEAD	4	4	
13	1NL-27424-00	DAMPER, FOOTREST 2	4	4	
14	90209-08295	WASHER	4	4	
15	3VD-27414-00	DAMPER, FOOTREST	2	2	
16	3VD-27311-01	STAND, SIDE	1	1	
17	90109-104E6	BOLT	1	1	
18	90185-10037	NUT, SELF-LOCKING	1	1	
19	90506-18224	SPRING, TENSION	1	1	
20	90506-26225	SPRING, TENSION	1	1	
21	1TX-27351-00	GUIDE, SIDE STAND	1	1	
22	3VD-27315-00	LINK, SIDE STAND	1	1	
23	4BR-27431-00	FOOTREST, REAR 1	1	1	
24	4BR-27441-00	FOOTREST, REAR 2	1	1	
25	90501-12743	SPRING, COMPRESSION	2	2	
26	93501-04011	BALL	2	2	
27	1HX-27437-00	WASHER, SPECIAL	4	4	

FIG. 34 STAND. FOOTREST

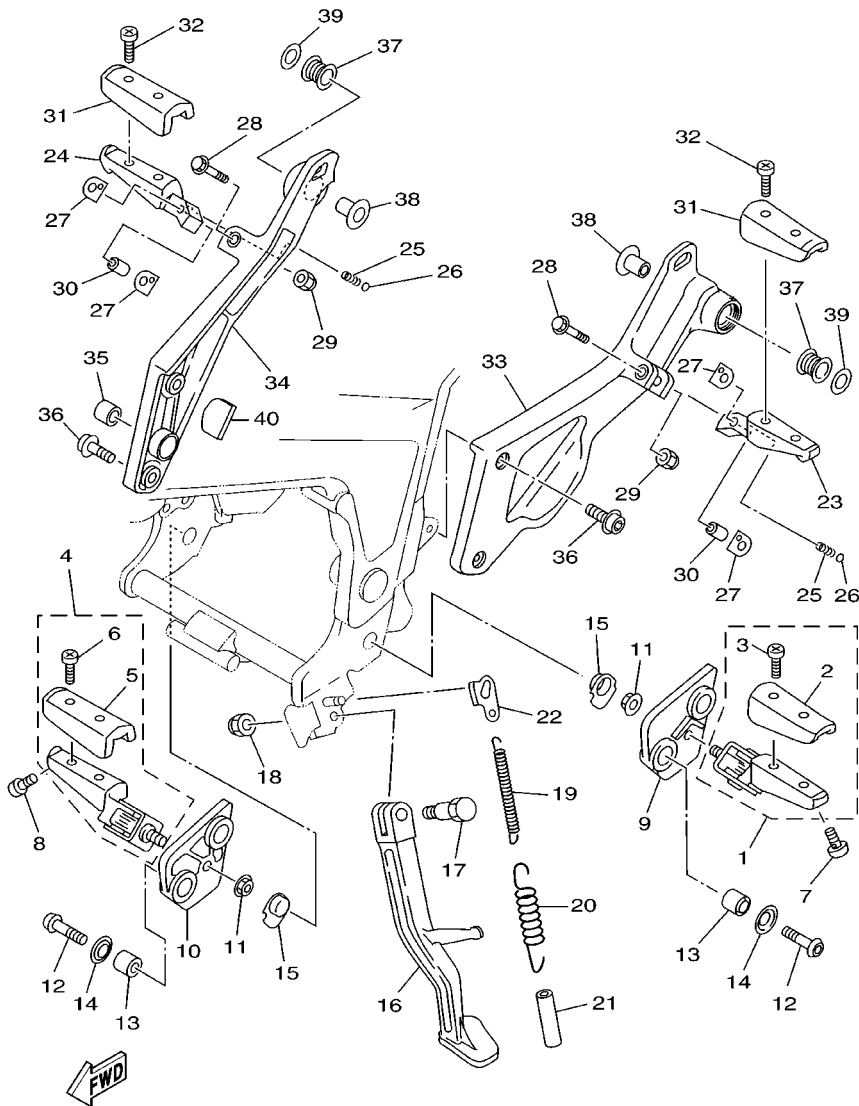

4TX1351-6341

REF. NO.	PART NO.	DESCRIPTION	4TX8	4TX9	REMARKS
28	95024-06045	BOLT, FLANGE	2	2	
29	95604-06200	NUT, U FLANGE	2	2	
30	90387-064H8	COLLAR	2	2	
31	2GH-27413-00	COVER, FOOTREST	2	2	
32	90157-05079	SCREW, PAN HEAD	4	4	
33	4TX-27412-00	BRACKET, FOOTREST 1	1	1	
34	4TX-27422-00	BRACKET, FOOTREST 2	1	1	
35	90380-20213	BUSH, SOLID	1	1	
36	90110-08199	BOLT, HEXAGON SOCKET HEAD	4	4	
37	36Y-27424-00	DAMPER, FOOTREST 2	2	2	
38	90387-104L8	COLLAR	2	2	
39	90201-10669	WASHER, PLATE	2	2	
40	3VD-2139X-00	DAMPER	1	1	

FIG. 35 REAR MASTER CYLINDER

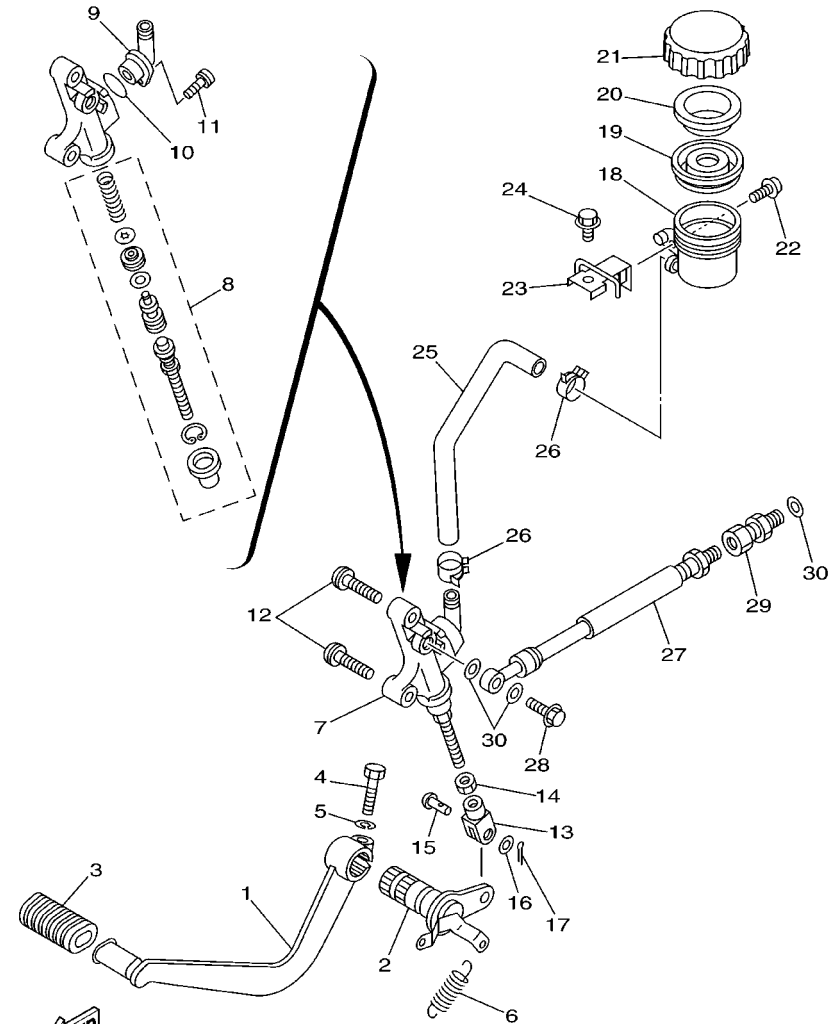

4TX4351-9350

REF. NO.	PART NO.	DESCRIPTION	4TX8	4TX9				REMARKS
1	3VD-27211-00	PEDAL, BRAKE	1	1				
2	3VD-27212-00	SHAFT, BRAKE PEDAL	1	1				
3	22N-18113-00	COVER, SHIFT PEDAL	1	1				
4	90101-06278	BOLT	1	1				
5	92907-06100	WASHER, SPRING	1	1				
6	90506-20192	SPRING, TENSION	1	1				
7	4TX-2583V-00	RR. MASTER CYLINDER ASSY.	1	1				
8	3VD-W0042-50	.CYLINDER KIT, MASTER	1	1				
9	3LN-2582A-00	.JOINT	1	1				
10	3LN-2585F-00	.O-RING	1	1				
11	3LN-2585H-00	.SCREW,SET	1	1				
12	92014-08020	BOLT, BUTTON HEAD	2	2				
13	47X-27222-00	JOINT	1	1				
14	95307-08700	NUT	1	1				
15	90240-08013	PIN, CLEVIS	1	1				
16	90201-08083	WASHER, PLATE	1	1				
17	91401-20012	PIN, COTTER	1	1				
18	47X-25894-00	TANK, RESERVOIR	1	1				
19	360-25854-01	DIAPHRAGM, RESERVOIR	1	1				
20	2GU-25855-00	BUSH,DIAPHRAGM	1	1				
21	2KF-25852-50	CAP, RESERVOIR	1	1				
22	90159-06056	SCREW, WITH WASHER	1	1				
23	3VD-2582E-10	HOLDER, RESERVE TANK	1	1				
24	95827-06010	BOLT, FLANGE	1	1				
25	3VD-25895-01	HOSE, RESERVOIR	1	1				
26	90467-14057	CLIP	2	2				
27	3VD-25872-51	HOSE, BRAKE 1	1	1				

FIG. 36 COWLING 1

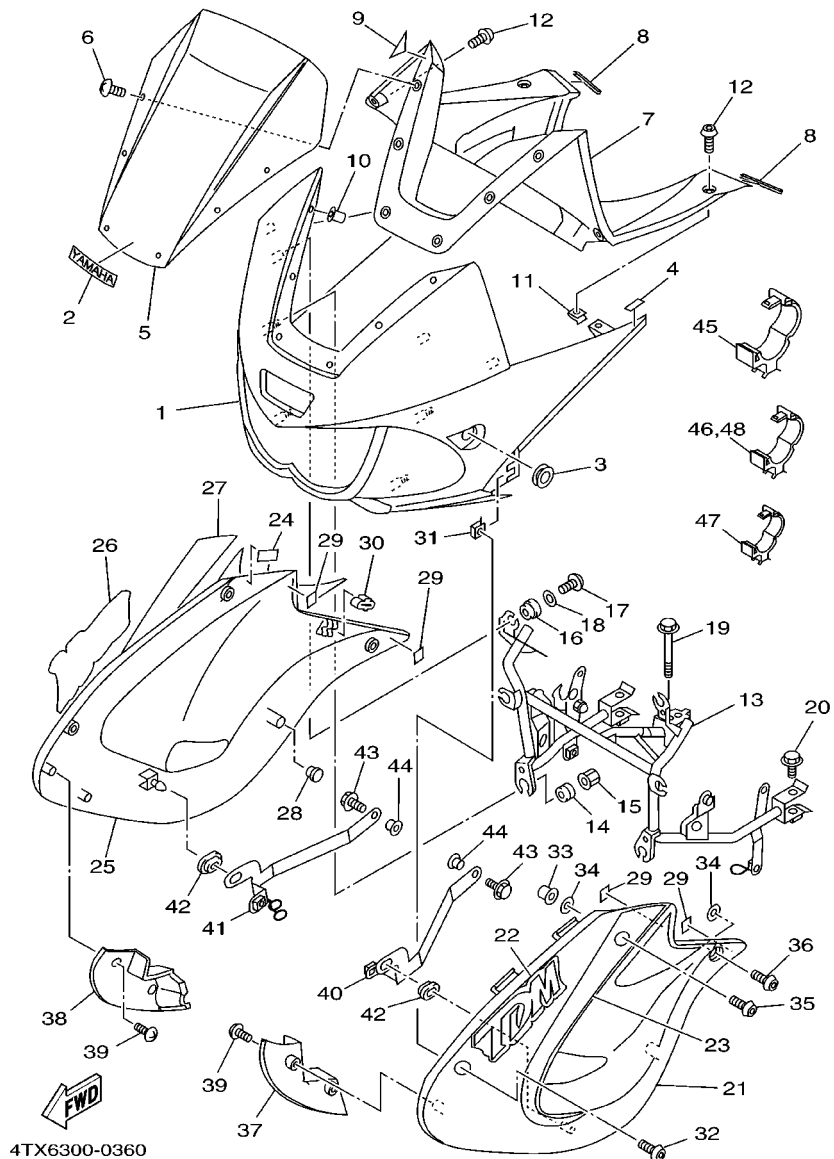

REF. NO.	PART NO.	DESCRIPTION	4TX8	4TX9	REMARKS
1	4TX-2835G-00-0X	BODY, FRONT UPPER 1	1		UR BL2/LGB
	4TX-2835G-00-8X	BODY, FRONT UPPER 1	1	1	UR BMC/LGB
	4TX-2835G-00-9X	BODY, FRONT UPPER 1	1	1	UR DPRC3/LGB
2	99247-00080	EMBLEM, YAMAHA	1	1	
3	4KM-28371-00	DAMPER	2	2	
4	4TX-21717-00	DAMPER	4	4	
5	4TX-28381-00	WINDSHIELD	1	1	
6	90150-05024	SCREW, ROUND HEAD	6	6	
7	4TX-2836K-40	PANEL, INNER 1	1	1	
8	4TX-28345-00	MOLE 1	2	2	
9	4TX-21649-00	DAMPER	2	2	
10	90179-05523	NUT	6	6	
11	90183-05042	NUT, SPRING	2	2	
12	90167-05076	SCREW, TAPPING	4	4	
13	4TX-28356-40	STAY 1	1	1	
14	90480-14229	GROMMET	4	4	
15	90179-06500	NUT	4	4	
16	90480-13426	GROMMET	2	2	
17	97707-40010	SCREW, TAPPING	2	2	
18	90201-052E8	WASHER, PLATE	2	2	
19	95817-08080	BOLT, FLANGE	1	1	
20	95817-08035	BOLT, FLANGE	2	2	
21	4TX-2835U-00-7M	PANEL 1	1		UR MDS FOR BL2
	4TX-2835U-00-4B	PANEL 1	1	1	UR BL2 FOR BMC
	4TX-2835U-00-P6	PANEL 1	1	1	UR PPBM3 FOR DPRC3
22	4TX-28328-90	EMBLEM	1		UR FOR BL2
	4TX-28328-A0	EMBLEM	1	1	UR FOR BMC

FIG. 36 COWLING 1

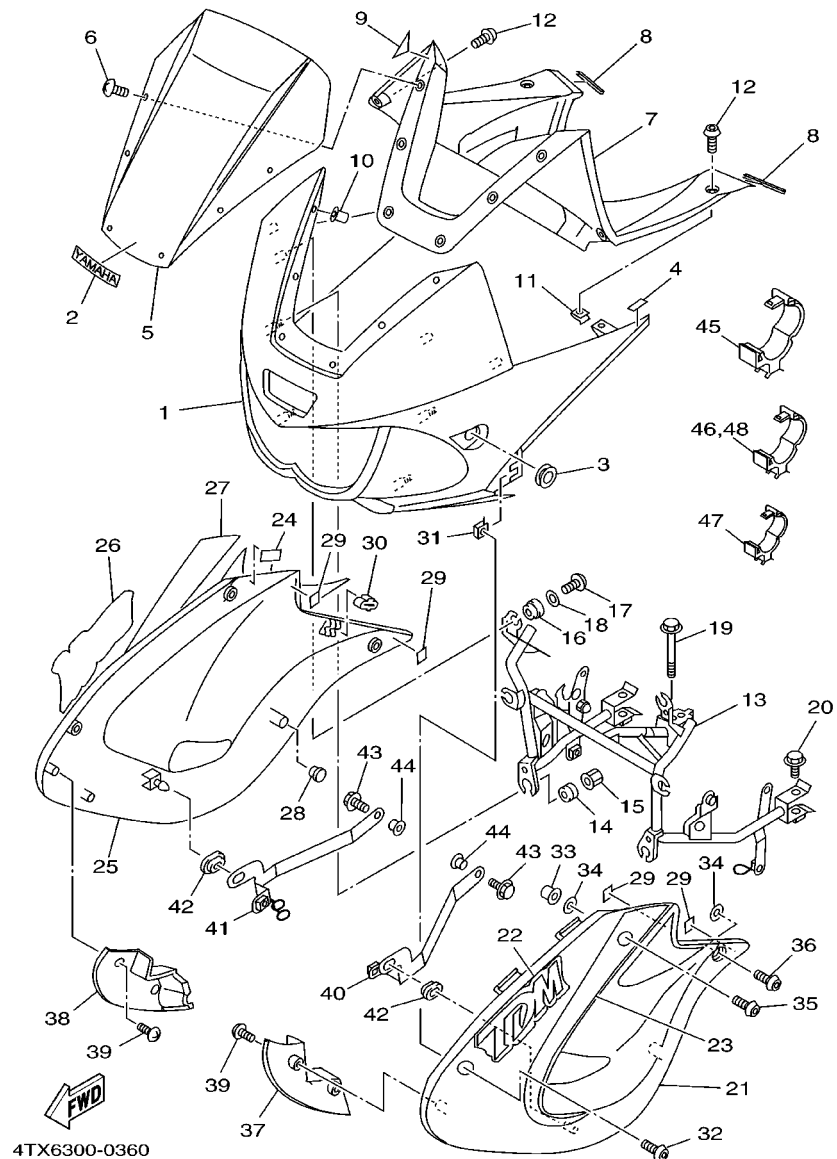

REF. NO.	PART NO.	DESCRIPTION	4TX8	4TX9	REMARKS
22	4TX-28328-B0	EMBLEM	1	1	UR FOR DPRC3
23	4TX-28301-00	GRAPHIC SET, LOWER COVER 1	1		UR FOR BL2
	4TX-28301-40	GRAPHIC SET, LOWER COVER 1	1	1	UR FOR BMC
	4TX-28301-50	GRAPHIC SET, LOWER COVER 1	1	1	UR FOR DPRC3
24	30X-2139X-00	DAMPER	2	2	
25	4TX-2835V-00-7M	PANEL 2	1		UR MDS FOR BL2
	4TX-2835V-00-4B	PANEL 2	1	1	UR BL2 FOR BMC
	4TX-2835V-00-P6	PANEL 2	1	1	URPPBM3 FORDPRC3
26	4TX-28338-90	EMBLEM	1		UR FOR BL2
	4TX-28338-A0	EMBLEM	1	1	UR FOR BMC
	4TX-28338-B0	EMBLEM	1	1	UR FOR DPRC3
27	4TX-28303-00	GRAPHIC SET, LOWER COVER 2	1		UR FOR BL2
	4TX-28303-40	GRAPHIC SET, LOWER COVER 2	1	1	UR FOR BMC
	4TX-28303-50	GRAPHIC SET, LOWER COVER 2	1	1	UR FOR DPRC3
28	90338-10132	PLUG	2	2	
29	2TV-21639-00	DAMPER 2	4	4	
30	15A-21717-00	DAMPER	2	2	
31	90183-05024	NUT, SPRING	2	2	
32	90110-05201	BOLT, HEXAGON SOCKET HEAD	2	2	
33	90179-05523	NUT	2	2	
34	90202-05224	WASHER, PLATE	4	4	
35	90149-05299	SCREW	2	2	
36	90110-05201	BOLT, HEXAGON SOCKET HEAD	2	2	
37	4TX-2837N-00	GRILL, AIR INTAKE 1	1	1	
38	4TX-2837R-00	GRILL, AIR INTAKE 2	1	1	
39	97707-50012	SCREW, TAPPING	4	4	
40	4TX-28321-00	STAY 1	1	1	

FIG. 38 FLASHER LIGHT

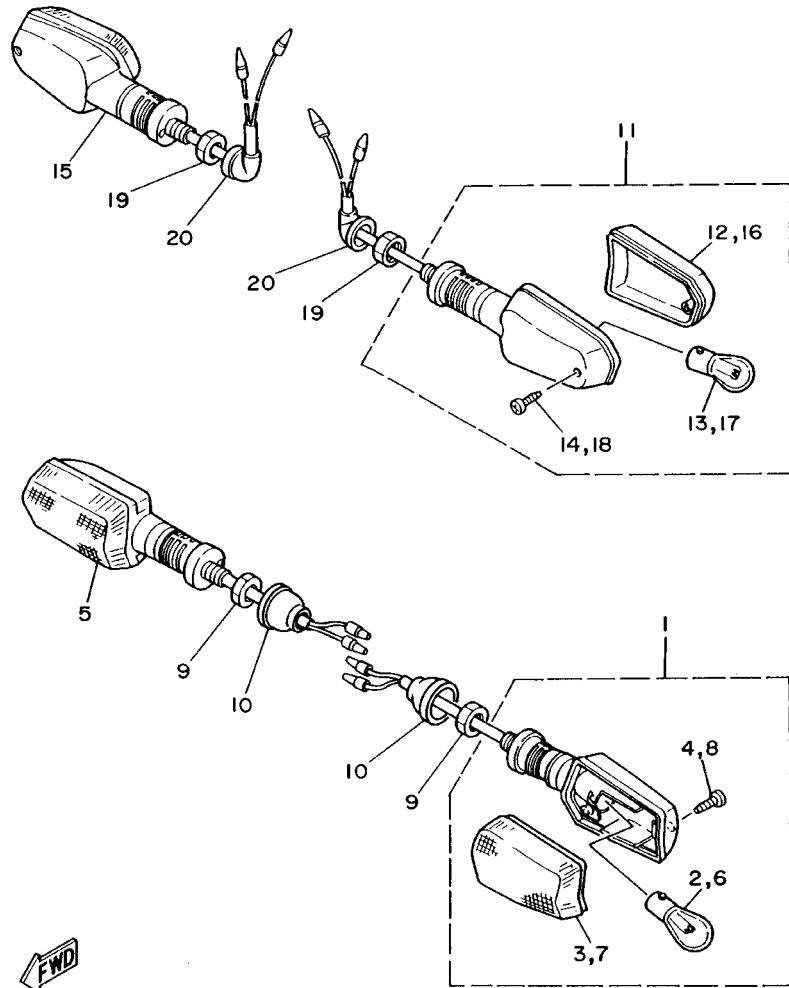

4TX1351-6380

REF. NO.	PART NO.	DESCRIPTION	4TX8	4TX9	REMARKS
1	3GM-83310-00	FRONT FLASHER LIGHT ASSY 1	1	1	
2	306-83311-40	.BULB, FLASHER (12V-21W)	1	1	
3	51L-83332-01	.LENS, FLASHER	1	1	
4	97707-40620	.SCREW, TAPPING	1	1	
5	3GM-83320-00	FRONT FLASHER LIGHT ASSY 2	1	1	
6	306-83311-40	.BULB, FLASHER (12V-21W)	1	1	
7	51L-83342-01	.LENS, FLASHER 2	1	1	
8	97707-40620	.SCREW, TAPPING	1	1	
9	95307-12700	NUT	2	2	
10	10V-83365-00	CAP	2	2	
11	3VD-83330-00	REAR FLASHER LIGHT ASSY 1	1	1	
12	1VU-83332-00	.LENS, FLASHER	1	1	
13	306-83311-40	.BULB, FLASHER (12V-21W)	1	1	
14	97706-40620	.SCREW, TAPPING	1	1	
15	3VD-83340-00	FLASHER LIGHT ASSY 2	1	1	
16	1VU-83342-00	.LENS, FLASHER 2	1	1	
17	306-83311-40	.BULB, FLASHER (12V-21W)	1	1	
18	97706-40620	.SCREW, TAPPING	1	1	
19	95307-12600	NUT	2	2	
20	18G-83365-00	CAP	2	2	

FIG. 39 METER

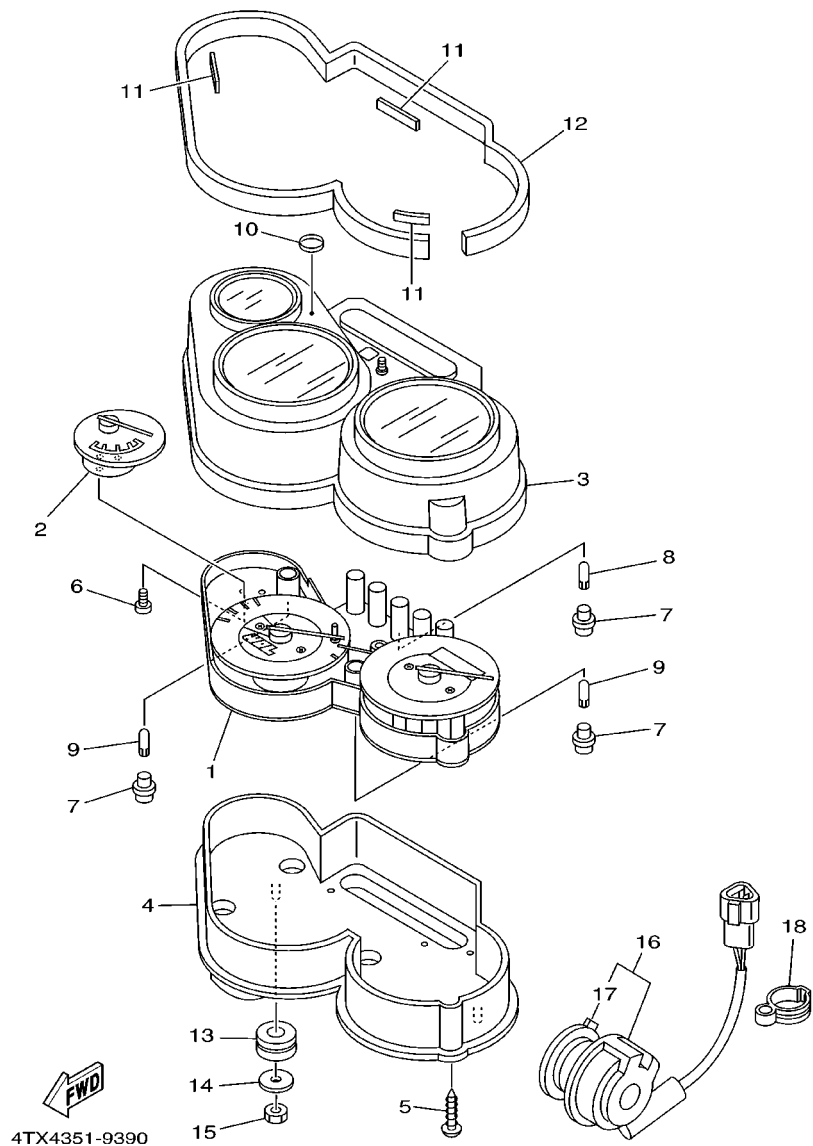

REF. NO.	PART NO.	DESCRIPTION	4TX8	4TX9	REMARKS
1	5DM-83570-21	SPEEDOMETER ASSY	1	1	UR
	5DM-83570-31	SPEEDOMETER ASSY	1		UR FOR GBR
2	4YR-85750-01	FUEL METER ASSY	1	1	
3	5DM-8353E-21	CASE, METER UPPER	1	1	
4	4YR-83572-00	CASE, SPEEDOMETER LOWER	1	1	

5	97707-40018	SCREW, TAPPING	7	7	
6	4YR-8362Y-00	SCREW, SPECIAL	3	3	
7	4YR-83534-00	SOCKET, NEUTRAL	9	9	
8	4YR-83517-00	BULB (12V-1.4W T5)	5	5	
9	4YR-83517-10	BULB (12V-2W T5)	4	4	

10	4XV-2341B-00	EMBLEM	1	1	
11	4TX-83526-40	DAMPER 2	3	3	
12	4TX-83523-40	DAMPER	1	1	
13	90480-14585	GROMMET	3	3	
14	90201-06380	WASHER, PLATE	3	3	

15	95307-06600	NUT	3	3	
16	4TX-83755-42	SENSOR, SPEED	1	1	
17	4TX-2517G-00	.ROTOR, SENSOR	1	1	
18	90465-14310	CLAMP	3	3	

FIG. 40 HEADLIGHT

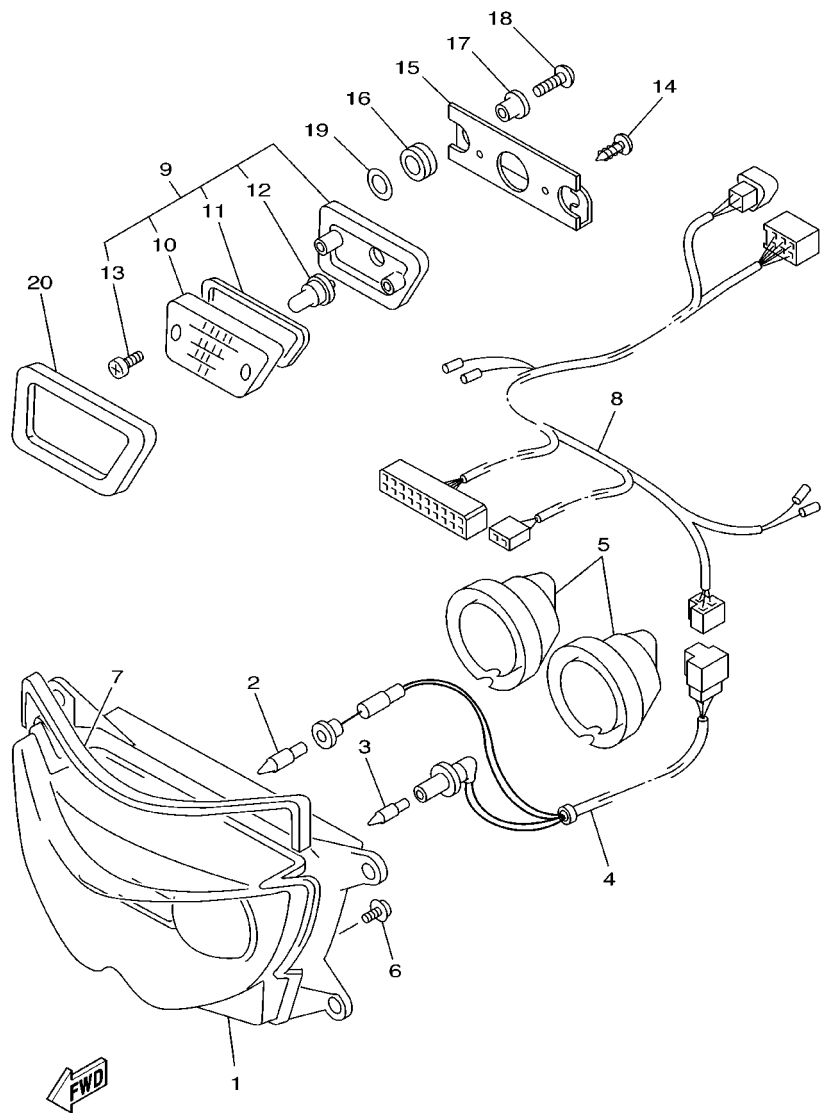

4TX4351-9400

REF. NO.	PART NO.	DESCRIPTION	4TX8	4TX9	REMARKS
1	4TX-84320-00	LENS ASSY	1		UR
	4TX-84320-10	LENS ASSY	1	1	UR FOR GBR
2	*	BULB (12V-55W-H3)	1	1	LM HALOGEN
3	*	BULB (12V-55W)	1	1	LM HALOGEN
4	3GM-84340-40	SOCKET CORD ASSY 1	1	1	
5	3GM-84397-40	COVER, SOCKET	2	2	
6	3TJ-84351-00	SCREW	1	1	
7	4TX-84163-00	DAMPER	1	1	
8	4TX-84359-10	CORD, HEADLIGHT	1	1	
9	3GM-84301-00	PILOT LIGHT ASSY 1	1	1	
10	3GM-84321-00	.LENS ASSY	1	1	
11	3GM-84322-00	.GASKET, LENS	1	1	
12	47G-85353-00	.BULB (12V-5W)	1	1	
13	3GM-84192-10	.SCREW, SPECIAL	2	2	
14	90167-05025	SCREW, TAPPING	2	2	
15	4TX-8431R-00	STAY, SETTING	1	1	
16	90480-10517	GROMMET	2	2	
17	90387-052U5	COLLAR	2	2	
18	90167-05037	SCREW, TAPPING	2	2	
19	90201-054K4	WASHER, PLATE	2	2	
20	3GM-84367-50	DAMPER, HEADLIGHT 2	1	1	

FIG. 41 TAILLIGHT

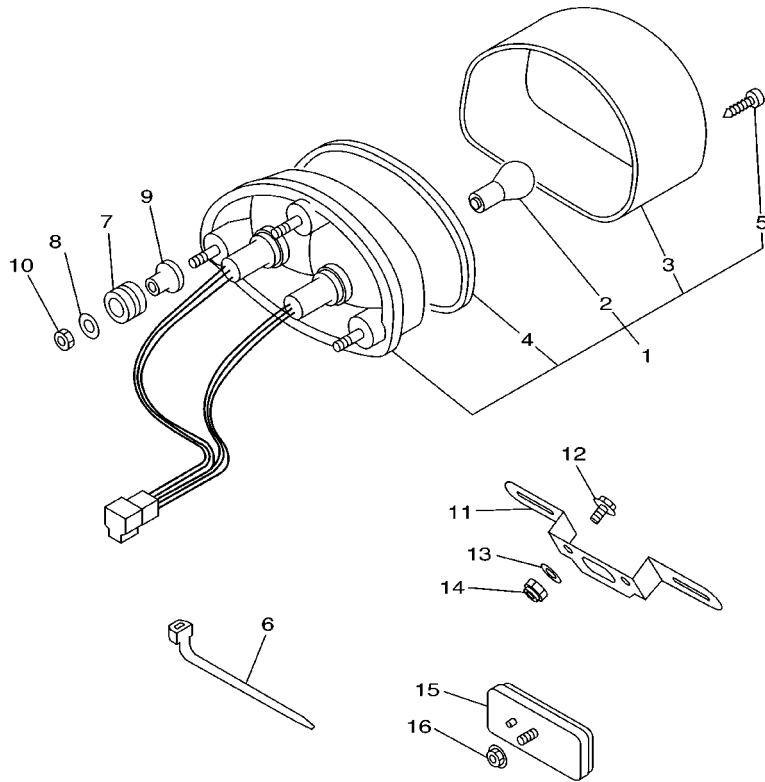

REF. NO.	PART NO.	DESCRIPTION	4TX8	4TX9	REMARKS
1	4TX-84710-00	TAILLIGHT UNIT ASSY	1	1	
2	31L-84714-00	.BULB, TAILLIGHT (12V-21/5W)	2	2	
3	4TX-84733-00	.LENS, TAILLIGHT	1	1	
4	4TX-84723-00	.GASKET, TAIL LENS	1	1	
5	97706-40620	.SCREW, TAPPING	2	2	
<hr/>					
6	90464-13077	CLAMP	1	1	
7	90480-18276	GROMMET	3	3	
8	90201-06071	WASHER, PLATE	3	3	
9	90387-077M3	COLLAR	3	3	
10	95307-06600	NUT	3	3	
<hr/>					
11	4TX-84751-00	BRACKET, LICENSE	1	1	
12	95027-06014	BOLT, FLANGE	2	2	
13	90201-06057	WASHER, PLATE	2	2	
14	95607-06100	NUT, U	2	2	
15	3Y6-85130-02	REAR REFLECTOR ASSY	1	1	UR
	4KM-85130-00	REAR REFLECTOR ASSY	1		UR FOR FIN,NOR,SWE
16	95707-05500	NUT, FLANGE	1	1	
<hr/>					
<hr/>					
<hr/>					



4TX1351-6410

FIG. 42 HANDLE SWITCH. LEVER

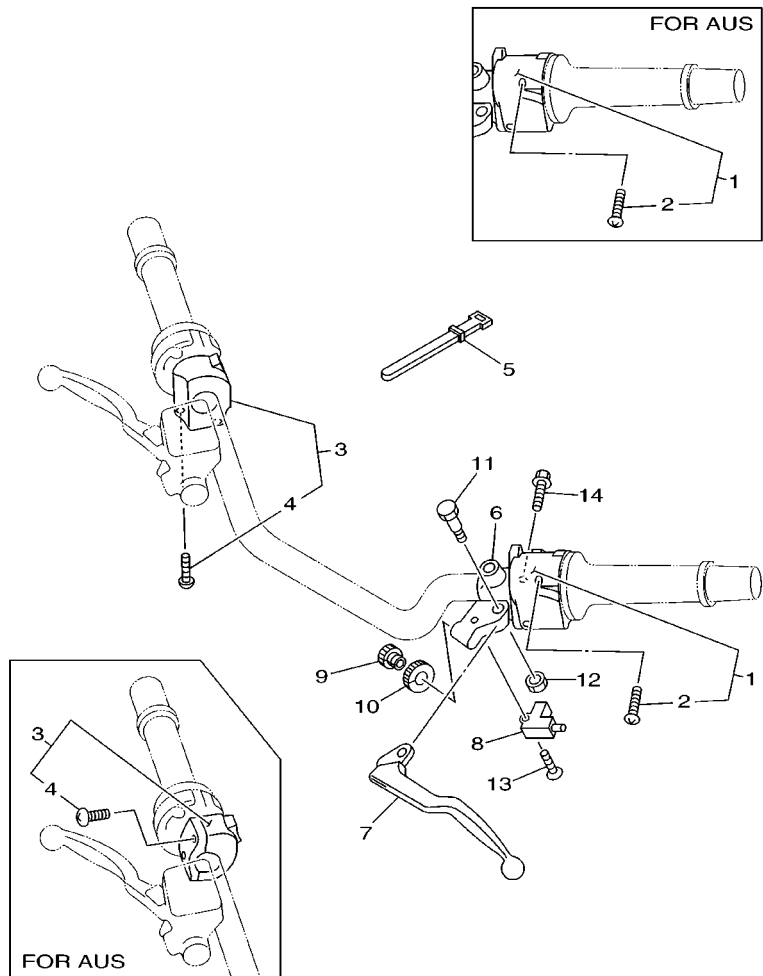

REF. NO.	PART NO.	DESCRIPTION	4TX8	4TX9	REMARKS
1	4TX-83969-40	SWITCH, HANDLE 5	1		
	4TX-83972-00	SWITCH, HANDLE 4		1	
2	98507-05025	.SCREW, PAN HEAD	2	2	
3	4TX-83963-40	SWITCH, HANDLE 3 (RIGHT)	1		
	4TX-83975-00	SWITCH, HANDLE 2		1	
4	98507-05045	.SCREW, PAN HEAD	2		
	98507-05022	.SCREW, PAN HEAD		2	
5	437-83936-01	BAND, SWITCH CORD	2	2	
6	3YX-82911-01	HOLDER, LEVER 1	1	1	
7	3YX-83912-00	LEVER 1	1	1	
8	3YX-82917-00	SWITCH	1	1	
9	90123-08096	BOLT	1	1	
10	90179-08148	NUT	1	1	
11	3YX-83945-00	BOLT, LEVER	1	1	
12	95607-06100	NUT, U	1	1	
13	98707-03020	SCREW, FLAT HEAD	1	1	
14	95027-06020	BOLT, FLANGE	1	1	

4TX4300-9420

FIG. 43 ELECTRICAL 1

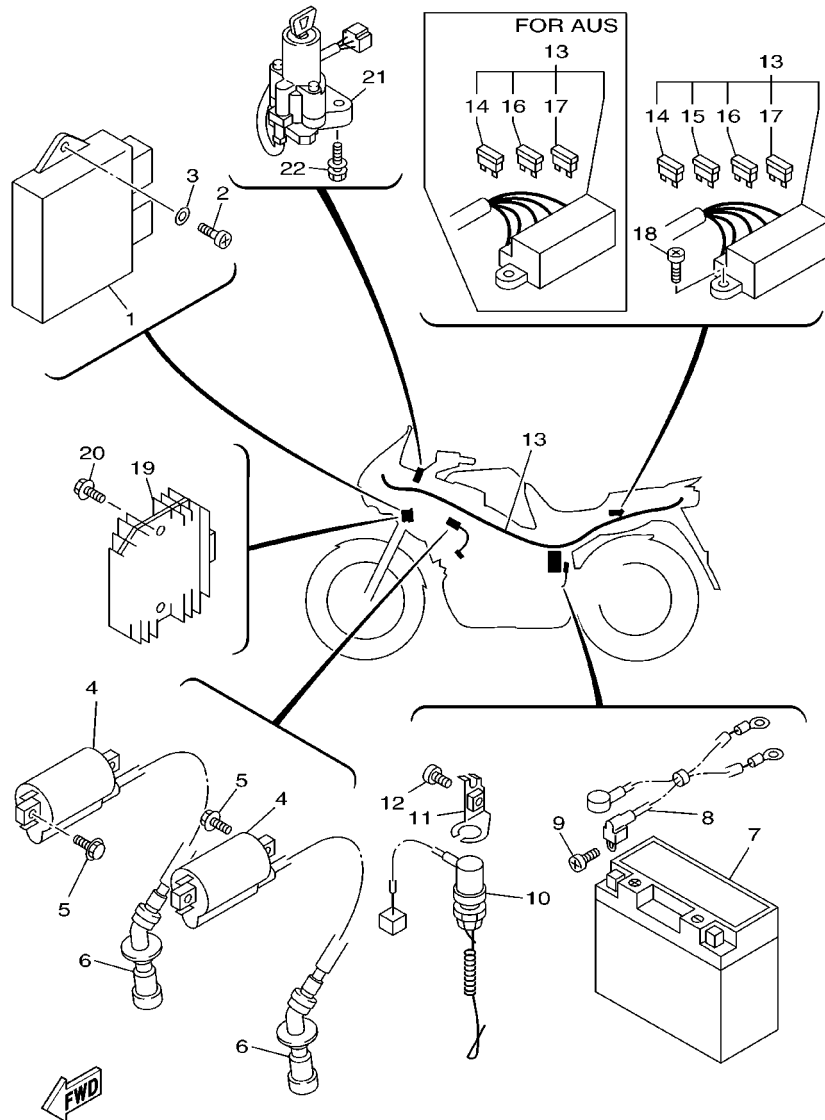

4TX4300-9430

REF. NO.	PART NO.	DESCRIPTION	4TX8	4TX9	REMARKS
1	4TX-82305-40	IGNITOR UNIT ASSY	1	1	
2	98507-06016	SCREW, PAN HEAD	2	2	
3	92907-06600	WASHER, PLATE	2	2	
4	3TB-82310-00	IGNITION COIL ASSY	2	2	
5	91317-05016	BOLT	4	4	
6	3LD-82370-00	PLUG CAP ASSY	2	2	
7	4TX-82100-01	BATTERY ASSY (GT12B-4)	1	1	
8	4TX-82509-00	WIRE, SUB LEAD	1	1	
9	98507-06008	SCREW, PAN HEAD	1	1	
10	4TX-82530-00	STOP SWITCH ASSY	1	1	
11	4TX-82539-00	STAY, STOP SWITCH	1	1	
12	92014-06010	BOLT, BUTTON HEAD	1	1	
13	4TX-82590-40	WIRE HARNESS ASSY	1		
	4TX-82590-50	WIRE HARNESS ASSY		1	
14	36Y-82151-00	.FUSE (15A-BL)	3		
	36Y-82151-00	.FUSE (15A-BL)		4	
15	42X-82151-00	.FUSE (10A-BL)	3		
16	1NL-82151-00	.FUSE (5A-BL)	2	2	
17	2KW-82151-00	.FUSE (7.5A-BL)	2	2	
18	98907-06012	SCREW, BIND	2	2	
19	4JH-81960-01	RECTIFIER & REGULATOR ASSY	1	1	
20	95807-06020	BOLT, FLANGE	2	2	
21	4JH-82501-04	MAIN SWITCH STEERING LOCK	1		
	4NA-82501-02	MAIN SWITCH STEERING LOCK		1	
22	90109-080G5	BOLT	2	2	

FIG. 44 ELECTRICAL 2

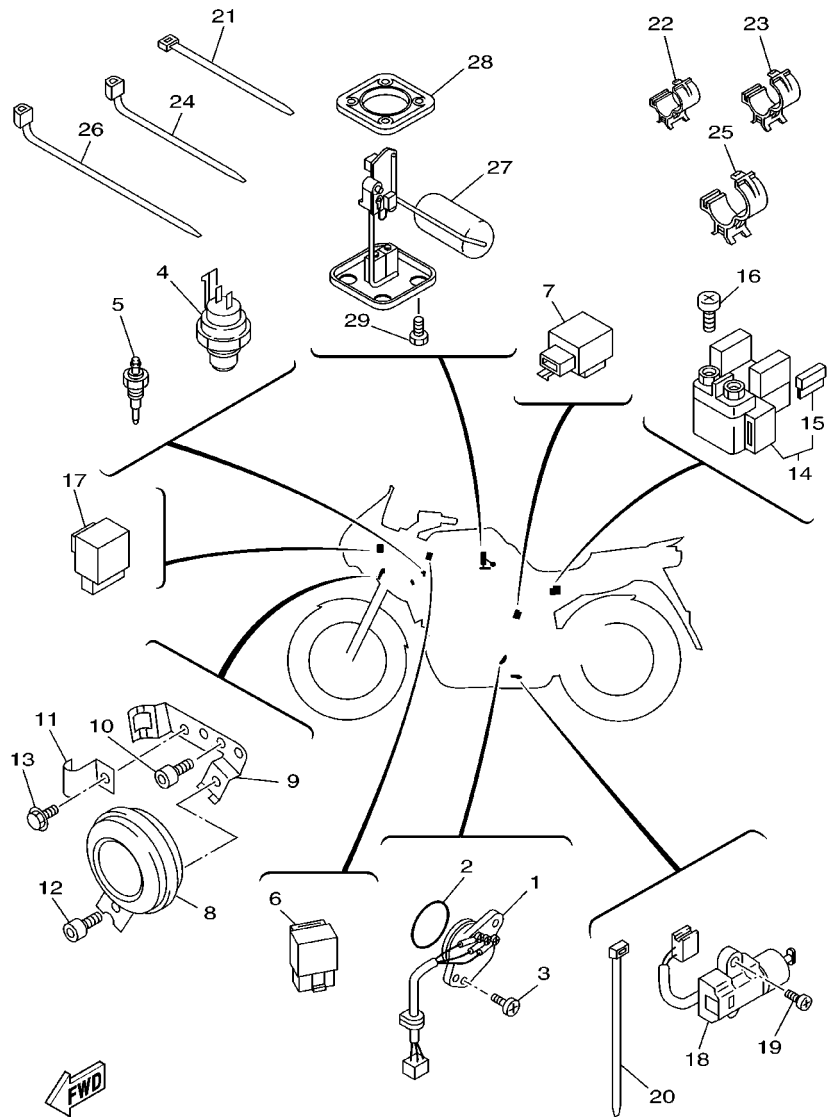

4TX6300-0440

REF. NO.	PART NO.	DESCRIPTION	4TX8	4TX9	REMARKS
1	4TX-82540-40	NEUTRAL SWITCH ASSY	1	1	
2	93210-29196	O-RING	1	1	
3	98507-06016	SCREW, PAN HEAD	2	2	
4	3LN-82560-01	THERMO SWITCH ASSY	1	1	
5	3YX-82560-00	THERMO SWITCH ASSY	1	1	
6	4KM-81950-00	RELAY ASSY	1		
7	3GM-83350-01	FLASHER RELAY ASSY	1	1	
8	4KM-83371-00	HORN	1	1	
9	4TX-23377-00	BRACKET, HORN	1	1	
10	91317-06014	BOLT	2	2	
11	4TX-23378-00	BRACKET, HORN	1	1	
12	91317-06010	BOLT	1	1	
13	95807-06010	BOLT, FLANGE	1	1	
14	4DN-81940-00	STARTER RELAY ASSY	1	1	
15	1AE-82151-00	.FUSE (30A-BL)	2	2	
16	98507-06008	SCREW, PAN HEAD	2	2	
17	3EN-81950-00	RELAY ASSY	1	1	
18	3LD-82566-50	SWITCH, SIDE STAND	1	1	
19	90157-05079	SCREW, PAN HEAD	2	2	
20	25G-83936-01	BAND, SWITCH CORD	2	2	
21	90464-25217	CLAMP	11	11	
22	90464-10190	CLAMP	6	6	
23	90464-15192	CLAMP	5	5	
24	90464-13073	CLAMP	1	1	
25	90464-20191	CLAMP	1	1	
26	90464-15195	CLAMP	1	1	
27	4TX-85752-40	SENDER UNIT ASSY, FUEL METER	1	1	

NUMERICAL INDEX

PARTNO.	GRID NO.	PARTNO.	GRID NO.	PARTNO.	GRID NO.	PARTNO.	GRID NO.	PARTNO.	GRID NO.	PARTNO.	GRID NO.
4BH-W0041-00	E - 11	3VD-11610-20	B - 4	3LD-12176-00	B - 8	3VD-13412-00	B - 12	4TX-14426-40	B - 15	3VD-15451-00	C - 9
3VD-W0042-50	E - 15	3VD-11610-40	B - 4	4NX-12181-00	B - 8	3VD-13414-00	B - 13	1AE-14451-00	B - 15	3VD-15456-00	C - 8
3GM-W0045-03	E - 6	4NX-11631-00	B - 4	3LD-12210-00	B - 8	3VD-13415-00	B - 12	1AE-14452-00	B - 15	4NX-15461-00	C - 10
4SV-W0045-50	E - 9	3LD-11633-00	B - 4	3VD-12213-00	B - 8	3VD-13416-00	B - 13	4BR-14452-00	B - 15	4NX-15462-01	C - 9
3HE-W0047-50	E - 6	4NX-11636-00	B - 4	3YL-12232-00	D - 4	4TX-13416-00	B - 14	4TX-14453-40	B - 15	3VD-15463-00	C - 10
31A-W0047-00	E - 9	4NX-11638-00	B - 4	3LD-12241-00	B - 8	3VD-13417-10	B - 13	4TX-14479-00	C - 3	1JK-15486-00	C - 9
1J3-W0048-00	E - 6	3VD-11650-00	B - 4	3LD-12247-00	B - 8	4NX-13418-00	B - 14	1FN-14565-00	C - 3	3LD-15512-00	C - 11
	E - 9	3LD-11654-00	B - 4	3LD-12251-00	B - 8	4X7-13440-01	B - 12	4WM-14565-00	C - 4	4NX-15515-00	C - 11
3HE-W0057-50	E - 6	3LD-11656-00	B - 4	3LD-12252-00	B - 8	3VD-13447-00	B - 12	4XY-14589-00	C - 4	3LD-15517-00	C - 11
31A-W0057-00	E - 9	3LD-11656-10	B - 4	4TX-12405-00	B - 10	4UN-13464-01	B - 13	4TX-14602-01	C - 6	26H-15521-00	C - 11
3YX-W0091-02	E - 11	3LD-11656-20	B - 4	1AE-12410-00	B - 11	4TX-13465-00	B - 13	3VD-14613-00	C - 6	3LD-15590-02	C - 11
3VD-W2165-00	D - 10	3LD-11656-30	B - 4	4TX-12413-00	B - 11	4TX-13467-00	B - 14	4TX-14710-42	C - 6	4TX-16150-01	C - 12
4TX-W2587-00	E - 11	3LD-12111-01	B - 6	4TX-12417-40	B - 11	11H-13490-00	B - 13	3VD-14755-00	C - 6	3VD-16154-00	C - 13
4NX-Y1119-10	B - 2	3LD-12112-01	B - 6	4TX-1243A-40	C - 4	3LD-13586-01	B - 15	4TX-1490J-40	C - 3	4H7-16154-00	C - 12
4UN-Y1242-00	B - 9	3LD-12113-00	B - 6	4TX-1243F-40	C - 4	3LD-13597-01	B - 15	4TX-1490J-50	C - 3	3VD-16164-00	C - 12
3VD-Y2151-10-PC	D - 5	1WG-12116-00	B - 6	1AA-12435-00	B - 10	4TX-13907-40	E - 2	3EN-1490K-00	C - 4	4NX-16181-00	C - 13
3VD-Y2151-10-PC	D - 5	3LD-12117-00	B - 6	1UF-12435-00	B - 10	4SV-1410A-00	C - 3	4TX-14900-40	C - 3	4H7-16321-02	C - 12
3VD-Y2151-10-7M	D - 5	3LD-12118-00	B - 6	1KT-12437-00	B - 10	4TX-14103-40	C - 4	4TX-14901-40	C - 3	4TX-16321-00	C - 12
3VD-Y2161-G0	D - 5	51Y-12119-00	B - 6	3LD-12439-00	B - 9	5DM-14105-00	C - 3	4TX-14902-40	C - 3	3J2-16324-00	C - 12
3VD-Y2161-01	D - 5	3LD-12121-00	B - 6	4TX-1244E-00	B - 11	4KM-14107-15	C - 3	5DM-14919-00	C - 4	4TX-16340-40	C - 12
4TX-Y2410-50-04	D - 15	1WG-12153-21	B - 6	3VD-12459-00	B - 9	4SV-14112-00	C - 3	4SV-14935-00	C - 4	3LD-16351-00	C - 12
4TX-Y2410-50-06	D - 15	1WG-12153-31	B - 6	4TX-12461-40	B - 10	4KM-14142-17	C - 3	5AP-14940-00	C - 4	3LD-1637A-01	C - 12
4TX-Y2410-50-07	D - 15	3LD-12168-A0	B - 6	4FL-12462-00	B - 10	36Y-14147-00	C - 4	4SV-14968-00	C - 3	4TX-16371-00	C - 12
3VD-Y1101-20	B - 2	3LD-12168-F0	B - 6	3VD-12465-00	B - 10	4TX-14148-00	C - 4	4SV-14985-00	C - 3	3LD-16382-00	C - 12
2GH-1111G-00	B - 2	3LD-12168-H1	B - 6	4TX-12465-00	B - 10	4TX-14148-10	C - 4	4SV-14987-00	C - 4	3LD-16398-00	C - 12
3LD-11133-10	B - 2	3LD-12168-K1	B - 6	1UF-12467-00	B - 10	4TX-14148-40	C - 5	3VD-15100-23	C - 7	4TX-17121-40	C - 14
3LD-11134-10	B - 2	3LD-12168-M1	B - 6	4UN-12469-00	B - 9	620-14186-00	C - 3	3LD-15118-00	C - 8	4TX-17131-40	C - 14
3LD-11160-02	B - 2	3LD-12168-R1	B - 6	3LD-12481-00	B - 9	4KP-14191-00	C - 3	2H7-15138-00	C - 7	2GH-17141-00	C - 14
4TX-11166-01	C - 2	3LD-12168-U1	B - 6	4NX-12482-00	B - 10	3JD-14197-00	C - 4	4G0-15138-00	C - 7	4TX-17151-40	C - 14
4NX-11181-00	B - 2	3LD-12168-W1	B - 6	1AA-12561-00	B - 10	3JE-14197-00	C - 4	4H7-15138-00	B - 13	4TX-17211-40	C - 14
3LD-11193-01	B - 2	3LD-12168-Y1	B - 6	4TX-12576-40	B - 11	4KM-14216-00	C - 4	3LD-15163-10	C - 14	4TX-17231-40	C - 14
214-11198-01	B - 13	3LD-12168-00	B - 6	4TX-12578-00	B - 10	1HX-1423A-68	C - 3	3LD-15191-00	C - 8	4NX-17241-00	C - 14
4UN-11310-00	B - 3	3LD-12168-20	B - 6	4NX-12579-00	B - 11	3G2-1423A-80	C - 3	3VD-15199-00	C - 7	4TX-17251-40	C - 14
3VD-11351-00	B - 3	3LD-12168-40	B - 6	1UF-12611-00	B - 10	1HX-14231-24	C - 3	3VD-15316-00	C - 7	4TX-17402-40	C - 14
3LD-11361-00	C - 7	3LD-12168-60	B - 6	26H-12630-00	B - 10	4HM-14239-00	C - 4	3VD-15317-00	C - 7	4TX-17411-40	C - 14
4NX-11400-00	B - 4	3LD-12168-80	B - 6	3LD-13113-00	B - 13	4TX-14261-00	C - 3	3VD-15326-00	C - 9	4NX-17471-00	C - 15
3LD-11416-00	B - 4	3LD-12169-E0	B - 7	4TX-13132-00	B - 14	4TX-14264-00	C - 4	3VD-15335-00	C - 9	3LD-18101-02	D - 3
3LD-11416-10	B - 4	3LD-12169-G0	B - 7	3LD-13151-00	B - 13	4TX-14275-00	C - 3	3F9-15362-00	B - 14	3VD-18110-10	D - 3
3LD-11416-20	B - 4	3LD-12169-J0	B - 7	3LD-13161-00	B - 12	4TX-14294-40	E - 2	3VD-15411-11	C - 9	132-18113-01	D - 3
3LD-11416-30	B - 4	3LD-12169-L0	B - 7	4TX-13266-00	B - 14	4NX-14327-00	C - 4	3LD-15414-00	C - 15	22N-18113-00	E - 15
3LD-11416-40	B - 4	3LD-12169-N0	B - 7	3LD-13300-00	B - 12	4TX-14348-00	C - 4	3VD-15416-10	C - 8	3VD-18115-00	D - 3
3LD-11416-50	B - 4	3LD-12169-T0	B - 7	4NX-13303-00	B - 12	4TX-14349-00	C - 4	3VD-15417-01	C - 9	4G0-18127-00	D - 3
3LD-11416-60	B - 4	3LD-12169-11	B - 6	3VD-13317-00	B - 14	4TX-14411-40	B - 15	3LD-15418-00	C - 9	3LD-18130-00	D - 3
4NX-11500-00	B - 4	3LD-12169-31	B - 6	3VD-13325-00	B - 12	4TX-14419-00	C - 4	3VD-15420-01	C - 9	4SV-18140-00	D - 2
4NX-11510-00	B - 4	3LD-12169-50	B - 6	3LD-13329-00	B - 12	3VD-1442G-00	B - 15	4UN-15425-01	C - 9	2H9-18154-00	D - 3
3LD-11583-00	B - 4	3LD-12169-70	B - 7	3LD-13339-00	B - 12	3VD-14421-00	B - 15	4UN-15426-00	C - 10	4NX-18175-00	D - 2
3LD-11584-00	B - 4	3LD-12169-90	B - 7	3LD-13371-00	B - 12	3VD-14422-00	B - 15	4UN-15430-00	C - 9	3VD-18511-00	D - 2
3VD-11610-00	B - 4	4NX-12171-00	B - 8	3VD-13411-00	B - 12	4TX-14425-40	B - 15	3LD-15449-00	C - 9	3VD-18512-00	D - 2

NUMERICAL INDEX

PARTNO.	GRID NO.	PARTNO.	GRID NO.	PARTNO.	GRID NO.	PARTNO.	GRID NO.	PARTNO.	GRID NO.	PARTNO.	GRID NO.
3VD-18513-00	D - 2	4TX-2173M-00	D - 8	4TX-23151-00	D - 14	3AJ-24523-00	D - 15	42H-25836-00	E - 9	3VD-27315-00	E - 13
4NX-18531-00	D - 2	4TX-21732-00	D - 8	4TX-23156-00	D - 13	3AJ-24534-00	D - 15	3YX-25838-00	E - 11	1TX-27351-00	E - 13
4NX-18535-00	D - 2	4TX-21735-00	D - 8		D - 14	1FK-24560-00	E - 2	3LN-2585F-00	E - 15	1UA-27410-00	E - 13
3LD-18536-00	D - 2	11H-21747-00	D - 4	4TX-23157-00	D - 13	1FK-24566-00	E - 2	3LN-2585H-00	E - 15	4TX-27412-00	E - 14
4TX-18540-40	D - 2	3Y6-21747-00	D - 8		D - 14	4FM-24602-10	E - 2	2KF-25852-50	E - 15	2GH-27413-00	E - 14
4UN-18542-00	D - 2	4TX-2177G-00	D - 8	4TX-23170-00	D - 13	4BH-24705-00	E - 4	4TX-25852-00	E - 11	46X-27413-00	E - 13
4UN-18566-00	D - 2	4TX-21781-A0	D - 5		D - 14	4TX-2471K-00-P6	D - 5	3YX-25854-00	E - 11	3VD-27414-00	E - 13
4TX-21110-40-35	D - 4		D - 6	4TX-23173-00	D - 13	4TX-2471K-00-4B	D - 5	360-25854-01	E - 15	1UA-27420-00	E - 13
4TX-21161-00	D - 4	4TX-21781-C0	D - 5		D - 14	4TX-24718-00	E - 4	2GU-25855-00	E - 15	4TX-27422-00	E - 14
3VD-21164-00	D - 4		D - 6	4TX-2319K-00	D - 13	4TX-2472K-00-P6	D - 6	3YX-25866-00	E - 11	1NL-27424-00	E - 13
4TX-2117E-00	D - 6	4TX-21781-D0	D - 5		D - 14	4TX-2472K-00-4B	D - 6	3YX-25866-10	E - 11	36Y-27424-00	E - 14
4KB-21268-00	D - 4		D - 6	4TX-2331E-00	D - 12	509-24724-00	E - 4	3YX-25867-00	E - 11	4BR-27431-00	E - 13
	D - 6	1AA-21815-00	D - 8	4TX-2331G-00	D - 13	4TX-24728-00	E - 4	4TX-25871-00	E - 11	2YK-27434-01	D - 3
46X-21269-00	D - 6	3VD-21816-00	D - 8		D - 14	4TX-24730-01	E - 4	3VD-25872-51	E - 15	1HX-27437-00	E - 13
4TX-2135F-01	D - 4	3VD-21871-00	D - 8	4TX-2331L-00	D - 13	4TX-24731-00	E - 4	4TX-27442-00	E - 11	4BR-27441-00	E - 13
3VD-21366-00	D - 5	1AA-21874-00	D - 8		D - 14	22W-24741-00	E - 4	4TX-25874-00	E - 11	3VD-27442-11	E - 13
4TX-21376-00	E - 4	4TX-22110-00	D - 10	4YR-23317-00	E - 6	4TX-24748-00	E - 4	3VD-25875-01	D - 10	3VD-27443-11	E - 13
3VD-2139X-00	E - 14	4X7-22129-00	D - 10	4TX-23340-00	D - 14	4TX-24776-01	E - 4	4TX-28100-00	E - 12	4TX-28100-00	D - 6
30X-2139X-00	E - 2	46X-22141-00	D - 10	4TX-23377-00	F - 13	4TX-2478F-00	E - 4	3YX-25880-00	E - 11	4TX-28301-00	F - 4
	F - 4	3VD-22151-00	D - 10	4TX-23378-00	F - 13	4TX-24796-00	E - 4	3LC-25885-00	F - 2	4TX-28301-40	F - 4
3VD-21411-10-35	D - 4	3HE-22174-00	E - 7	4TX-23389-00	D - 12	3VD-25168-00-7B	E - 5	3YX-2589F-00	E - 11	4TX-28301-50	F - 4
4TX-21419-00-35	D - 4	33M-22184-00	D - 10	4XV-2341B-00	F - 8	4TX-2517G-00	F - 8	47X-25894-00	E - 15	4TX-28303-00	F - 4
3LD-2143A-00	D - 4	4TX-22210-00	D - 11	1W1-23416-00	D - 12	3GM-25181-03	E - 5	3VD-25895-01	E - 15	4TX-28303-40	F - 4
3VD-2143A-00	D - 4	3VD-22216-00	D - 11	26H-23418-01	D - 12	3VD-25338-00-7B	E - 7	29L-25919-00	E - 9	4TX-28303-50	F - 4
4TX-2148U-40	D - 4	3VD-22311-00	D - 10	4TX-23435-00	D - 12	4TX-25364-40	E - 7	3GM-25919-00	E - 6	4TX-28321-00	F - 4
3VD-21489-00	D - 4	3VD-22464-00	D - 11	4H7-23441-00-PO	D - 12	1AE-25366-00	E - 7	3HE-25924-00	E - 6	4TX-28322-00	F - 5
4X7-2149Y-00	E - 2	4TX-23102-01	D - 13	3FV-23462-00	D - 12	3AJ-25381-01	E - 7		E - 9	4TX-28328-A0	F - 3
3GM-21512-00	D - 5	4TX-23103-01	D - 13	4TX-2411K-00	D - 15	4BP-25388-00	E - 7	3GM-25925-00	E - 6	4TX-28328-B0	F - 4
3FY-21575-01	D - 5	4TX-2311G-00	D - 13	3VD-24181-00	D - 15	29L-25398-00	E - 5		E - 9	4TX-28328-90	F - 3
4TX-2161A-00	D - 6		D - 14	4NO-24181-00	B - 15		E - 7	3VD-26111-20	E - 10	4TX-28338-A0	F - 4
3LD-21621-01	D - 6	4TX-2311H-00	D - 13	3Y6-24183-00	D - 15	29L-25398-10	E - 5	4TX-26131-10	E - 12	4TX-28338-B0	F - 4
50M-21638-00	D - 8		D - 14	47X-24183-00	D - 15		E - 7	3FH-26240-00	E - 10	4TX-28338-90	F - 4
2MG-21639-00	D - 5	4TX-23110-00	D - 13	2GH-24184-00	D - 15	29L-25398-20	E - 5	1KG-26241-00	E - 10	4TX-28345-00	F - 3
2TV-21639-00	F - 4	4TX-23115-00	D - 13	12R-24186-00	D - 15		E - 7	51J-26246-01	E - 10	4TX-2835G-00-OX	F - 3
51Y-21639-00	D - 8		D - 14	47X-24186-00	D - 15	4TX-25443-40	E - 7	3VP-26261-00	E - 10	4TX-2835G-00-8X	F - 3
	D - 9	4KM-23123-01	D - 14	4TX-24191-00	D - 15	3HE-2580T-70	E - 6	4TX-26280-41	E - 10	4TX-2835G-00-9X	F - 3
3VD-2164F-00	D - 10	4TX-23125-A0	D - 13	4TX-24192-00	D - 15	3HE-2580U-70	E - 6	3XW-26281-01	E - 10	4TX-2835U-00-P6	F - 3
3VD-21645-00-PB	D - 6		D - 14	4TX-24240-A0	D - 15	4TX-2580W-00	E - 9	3XW-26282-01	E - 10	4TX-2835U-00-4B	F - 3
3VD-21645-00-4B	D - 6	4TX-23126-01	D - 13	4TX-24240-C0	D - 15	4HM-2581T-01	E - 6	4TX-26290-41	E - 10	4TX-2835U-00-7M	F - 3
4TX-21649-00	F - 3	4TX-23135-A0	D - 13	4TX-24240-80	D - 15	3VD-25819-00	E - 9	4TX-26292-00	E - 10	4TX-2835V-00-P6	F - 4
4TX-21651-00-P6	D - 6	4TX-23136-01	D - 13	4TX-24311-40	E - 2	3LN-2582A-00	E - 15	4TX-26302-40	E - 10	4TX-2835V-00-4B	F - 4
4TX-21651-00-4B	D - 6	4TX-23141-00	D - 13	4TX-24315-40	E - 2	3VD-2582E-10	E - 15	4TX-26331-40	E - 10	4TX-2835V-00-7M	F - 4
4TX-21652-01	D - 9		D - 14	4SV-24411-00	C - 3	4HM-2582W-00	E - 9	4TX-26334-40	E - 10	4TX-28356-40	F - 3
3YX-2171L-00	D - 4	4TX-23144-00	D - 13	4XV-24453-00	C - 4	1FK-25827-00	E - 9	4TX-26335-01	E - 10	4TX-2836K-40	F - 3
4TX-21711-00	D - 8		D - 14	3CV-24491-10	E - 2	1FK-25828-00	E - 9	3VD-27211-00	E - 15	4TX-2837N-00	F - 4
15A-21717-00	F - 4	4TX-23145-00	D - 13	4KM-24500-10	D - 15	3YX-2583H-00	E - 11	3VD-27212-00	E - 15	4TX-2837R-00	F - 4
4TX-21717-00	F - 3		D - 14	4X8-24512-00	D - 15	4TX-2583V-00	E - 15	47X-27222-00	E - 15	4KM-28371-00	F - 3
4TX-21721-00	D - 9	4TX-23151-00	D - 13	4TX-2452E-40	E - 2	1KT-25836-00	E - 6	3VD-27311-01	E - 13	4TX-28381-00	F - 3

NUMERICAL INDEX

PARTNO.	GRID NO.	PARTNO.	GRID NO.	PARTNO.	GRID NO.	PARTNO.	GRID NO.	PARTNO.	GRID NO.	PARTNO.	GRID NO.
4TX-81410-00	F - 6	1VU-83342-00	F - 7	3HE-85132-01	D - 5	90116-10485	E - 7	90201-047A2	D - 7	90209-29329	C - 14
4TX-81450-00	F - 6	51L-83342-01	F - 7	47G-85353-00	F - 9	90119-05071	F - 14	90201-052E8	F - 3	90215-20231	C - 12
3AJ-81801-00	C - 11	3GM-83350-01	F - 13	4YR-85750-01	F - 8	90119-06044	D - 10	90201-054K4	F - 9	90215-21290	C - 14
3AJ-81809-00	C - 11	10V-83365-00	D - 11	4TX-85752-40	F - 13	90119-06056	D - 8	90201-06057	F - 10	90240-08013	E - 15
3LD-81815-01	C - 11		F - 7	4TX-85753-00	F - 14	90119-06108	D - 10	90201-06063	C - 2	90267-32071	D - 5
4XV-8182A-00	C - 11	18G-83365-00	F - 7	4TX-85885-00	C - 4	90123-08096	F - 11	90201-06071	B - 10	90267-40035	D - 5
3AJ-81826-00	C - 11	4KM-83371-00	F - 13	90101-06278	E - 15	90149-04278	D - 7		D - 8	90267-40073	D - 5
3AJ-81830-00	C - 11	4YR-83517-00	F - 8	90101-06576	C - 6	90149-05299	F - 4		F - 10	90267-40105	D - 10
11H-81844-00	C - 11	4YR-83517-10	F - 8	90101-10659	D - 11	90149-05321	D - 2	90201-06380	F - 8	90280-05029	B - 5
1FK-81847-00	C - 11	4TX-83523-40	F - 8	90105-06131	C - 10	90149-06011	D - 15	90201-066F0	C - 7	90338-05194	B - 15
4G0-81871-00	C - 11	4TX-83526-40	F - 8	90105-06153	B - 2	90149-06285	C - 8		C - 8	90338-08163	D - 12
3LD-81890-00	C - 11	5DM-8353E-21	F - 8	90105-06397	D - 2	90149-06286	C - 14	90201-08083	E - 15	90338-08174	E - 3
4DN-81940-00	F - 13	4YR-83534-00	F - 8	90105-06446	D - 4	90150-05024	F - 3	90201-08087	C - 7	90338-10132	F - 4
3EN-81950-00	F - 13	5DM-83570-21	F - 8	90105-06456	B - 13	90153-06029	B - 3	90201-08326	C - 6	90338-10150	B - 2
4KM-81950-00	F - 13	5DM-83570-31	F - 8		C - 9	90157-05079	E - 13		D - 3	90338-11257	C - 7
4JH-81960-01	F - 12	4YR-83572-00	F - 8	90105-06477	D - 5		E - 14	90201-10118	E - 11	90338-12192	D - 5
4TX-82100-01	F - 12	4YR-8362Y-00	F - 8	90105-06553	B - 13		F - 13		F - 2	90340-14132	B - 13
116-82131-00	D - 6	4TX-83755-42	F - 8		B - 14	90159-06056	E - 15	90201-10119	C - 12	90340-14151	C - 10
133-82131-00	D - 6	3YX-83912-00	F - 11	90105-06556	D - 12	90159-06059	D - 9	90201-103M4	B - 2	90340-18101	B - 2
1AE-82151-00	F - 13	3YX-83922-00	E - 11	90105-06557	D - 2	90159-06093	D - 8	90201-10430	D - 4	90340-32116	C - 10
1NL-82151-00	F - 12	25G-83936-01	F - 13	90105-06597	D - 2	90159-06123	C - 12	90201-10437	E - 9	90380-20213	E - 14
2KW-82151-00	F - 12	437-83936-01	F - 11	90105-07342	B - 8	90167-05025	F - 9	90201-10669	E - 14	90384-18190	D - 11
36Y-82151-00	F - 12	3YX-83945-00	F - 11	90105-08752	D - 4	90167-05037	F - 9	90201-11597	C - 7	90387-052U5	F - 9
42X-82151-00	F - 12	4TX-83963-40	F - 11	90105-10271	C - 6	90167-05076	F - 3	90201-121H0	B - 5	90387-0614M	B - 10
4TX-82305-40	F - 12	4TX-83969-40	F - 11	90105-10328	D - 4	90170-06228	D - 3	90201-12163	C - 12	90387-062L2	E - 2
3TB-82310-00	F - 12	4TX-83972-00	F - 11	90105-10560	C - 7	90170-20327	C - 12	90201-124G9	D - 11	90387-064H8	E - 14
3LD-82370-00	F - 12	4TX-83975-00	F - 11	90105-10638	E - 6	90176-22081	D - 12	90201-12575	D - 3	90387-064J1	D - 5
4JH-82501-04	F - 12	4BH-83980-00	E - 11		E - 9	90179-05523	F - 3	90201-127E1	B - 9		D - 10
4NA-82501-02	F - 12	4TX-84163-00	F - 9	90105-12584	B - 5		F - 4	90201-150U6	C - 12	90387-065T2	D - 5
4TX-82509-00	F - 12	3GM-84192-10	F - 9	90109-062G1	B - 2	90179-06500	F - 3	90201-160T2	E - 8	90387-06605	D - 15
4TX-82530-00	F - 12	3GM-84301-00	F - 9	90109-062G2	B - 2	90179-06635	E - 4	90201-161J3	D - 10	90387-06681	D - 10
4TX-82539-00	F - 12	4TX-8431R-00	F - 9	90109-064F0	B - 2	90179-08148	F - 11	90201-170T3	E - 7	90387-06761	B - 14
4TX-82540-40	F - 13	4TX-84320-00	F - 9	90109-080G5	F - 12	90179-08345	C - 6	90201-191J4	D - 3	90387-0714B	B - 10
3LN-82560-01	F - 13	4TX-84320-10	F - 9	90109-083E2	E - 13	90179-09379	B - 4	90201-200K3	C - 14	90387-07391	B - 15
3YX-82560-00	F - 13	3GM-84321-00	F - 9	90109-083G1	D - 4	90179-10247	E - 13	90201-20278	C - 15	90387-07674	D - 8
3LD-82566-50	F - 13	3GM-84322-00	F - 9	90109-083G4	E - 6	90179-10377	D - 4	90201-220T0	D - 12	90387-077M3	F - 10
4TX-82590-40	F - 12	3GM-84340-40	F - 9		E - 9	90179-10414	B - 2	90201-301P3	C - 11	90387-085N0	B - 14
4TX-82590-50	F - 12	3TJ-84351-00	F - 9	90109-085E2	D - 6	90179-18667	C - 15	90202-05193	E - 2	90387-0910H	F - 5
1UA-82591-00	E - 11	4TX-84359-10	F - 9	90109-086A0	D - 15	90179-25033	D - 12	90202-05224	F - 4	90387-104L8	E - 14
3YX-82911-01	F - 11	3GM-84367-50	F - 9	90109-104E6	E - 13	90183-05024	B - 10	90202-24190	D - 12	90387-106W6	B - 13
3YX-82917-00	F - 11	3GM-84397-40	F - 9	90109-125F1	D - 11		D - 6	90202-26142	D - 12		B - 14
3GM-83310-00	F - 7	4TX-84710-00	F - 10	90110-05112	E - 2		F - 4	90206-12074	D - 3	90387-120W5	B - 12
306-83311-40	F - 7	31L-84714-00	F - 10	90110-05201	F - 4	90183-05042	F - 3	90209-05279	C - 9	90387-127X0	D - 11
3GM-83320-00	F - 7	4TX-84723-00	F - 10	90110-06093	B - 14	90183-06023	D - 5	90209-08295	E - 13	90387-130W6	B - 14
3VD-83330-00	F - 7	4TX-84733-00	F - 10	90110-08071	E - 13	90183-06053	D - 8	90209-11262	B - 2	90387-173M5	E - 7
1VU-83332-00	F - 7	4TX-84751-00	F - 10	90110-08199	E - 14	90185-10037	E - 13	90209-21332	C - 14	90387-177K0	E - 7
51L-83332-01	F - 7	3Y6-85130-02	F - 10	90110-10229	D - 4	90185-14112	D - 10	90209-28330	C - 14	90387-177R1	E - 5
3VD-83340-00	F - 7	4KM-85130-00	F - 10	90116-08548	B - 2	90201-04018	D - 5	90209-28331	C - 14	90387-177Y4	E - 8

NUMERICAL INDEX

PARTNO.	GRID NO.	PARTNO.	GRID NO.	PARTNO.	GRID NO.	PARTNO.	GRID NO.	PARTNO.	GRID NO.	PARTNO.	GRID NO.
90387-177Y5	E - 8	90465-20035	B - 15	91314-10025	D - 4	93210-12095	C - 7	9384E-16191	C - 14	95301-06600	E - 11
90387-203M7	C - 14	90465-20342	C - 10	91314-10045	D - 4	93210-12790	B - 13	93900-00030	E - 5	95304-06700	D - 3
90387-253M6	C - 14	90467-08017	B - 15	91314-10060	D - 4		B - 14		E - 7	95307-06600	F - 8
90387-2802W	C - 14	90467-08075	B - 15	91317-05010	E - 2	93210-13657	B - 13	94111-1810C	E - 5		F - 10
90401-10106	B - 12		D - 8	91317-05016	F - 6		B - 14	94115-1710D	E - 7	95307-08600	E - 7
90401-10159	E - 11	90467-09006	E - 2		F - 12	93210-14369	C - 10	94581-46114	E - 7	95307-08700	E - 15
	F - 2	90467-09037	C - 4	91317-06010	F - 13	93210-15566	B - 14	94591-40138	B - 8	95307-12600	F - 7
90430-06014	B - 3	90467-10041	E - 3	91317-06014	F - 13	93210-16629	B - 14	94701-00241	B - 2	95307-12700	F - 7
	B - 9	90467-11090	B - 11	91317-06016	B - 11	93210-18N01	D - 13	94701-00242	B - 2	95604-06200	E - 14
90430-08119	B - 2	90467-11106	E - 2	91317-06018	C - 11		D - 14	95024-06010	D - 4	95604-16200	E - 8
90430-10171	D - 13	90467-12053	E - 2	91317-06020	B - 15	93210-18417	B - 11	95024-06012	B - 9	95606-06100	E - 11
	D - 14	90467-14057	E - 15	91317-06025	D - 8	93210-21190	B - 9	95024-06020	B - 9	95607-04100	D - 7
90430-10188	B - 12	90467-15012	C - 5	91317-06150	B - 2	93210-26741	B - 14		B - 12	95607-06100	F - 10
	B - 13	90467-22080	C - 2	91317-08040	D - 14	93210-27370	B - 14		C - 8		F - 11
90430-14131	B - 12	90467-24113	C - 2	91317-08110	C - 6	93210-29196	F - 13	95024-06025	B - 13	95607-06200	E - 2
90445-086J6	D - 8	90480-01558	F - 5	91317-10025	D - 13	93210-30660	B - 5		C - 9	95607-10200	E - 7
90445-090E5	B - 15	90480-01603	D - 9		D - 14	93210-32172	C - 10		E - 11	95607-12100	D - 11
90445-106J2	E - 2	90480-10258	D - 5	91317-10030	D - 14	93210-33133	B - 9	95024-06030	B - 9	95617-10100	D - 11
90445-11153	E - 2	90480-10517	F - 9	91401-20012	E - 15		C - 15		B - 12	95707-05500	E - 4
90445-112E1	E - 2	90480-12550	D - 6	92014-06010	F - 12	93210-34504	D - 13		C - 9		F - 10
90450-32015	B - 11	90480-13163	E - 2	92014-08020	E - 15		D - 14	95024-06035	C - 10	95707-10500	C - 6
	B - 14	90480-13369	D - 8	92017-06012	D - 6	93210-357A2	B - 9	95024-06040	B - 12	95807-06010	D - 4
90450-38040	B - 10	90480-13426	F - 3	92017-06035	D - 15	93210-44545	B - 15	95024-06045	B - 9		F - 13
	B - 14	90480-14229	F - 3	92906-04600	E - 11	93210-49046	B - 11		C - 10	95807-06012	F - 5
90450-57034	B - 15	90480-14585	F - 8	92907-04100	C - 3	93210-64297	B - 12		E - 14	95807-06016	E - 2
90450-75083	B - 15	90480-14604	B - 15	92907-04600	B - 2	93210-90785	B - 3	95024-06055	C - 9	95807-06020	F - 12
90460-27270	B - 13	90480-15363	B - 10		B - 11	93306-20314	E - 7		C - 10	95807-06025	B - 10
90461-06087	C - 4	90480-16233	D - 8	92907-05600	B - 10	93306-20455	C - 15	95024-06060	B - 9	95814-06040	C - 7
90462-20223	C - 10	90480-16404	D - 8		B - 15	93306-20464	C - 14	95024-06110	C - 10		C - 8
90464-10190	D - 8	90480-18276	F - 10	92907-06100	E - 15	93306-30319	E - 5	95024-08012	B - 2	95814-08050	C - 7
	F - 13	90501-06022	D - 2	92907-06600	D - 10	93306-30320	E - 7	95024-10040	B - 13	95814-08060	C - 7
90464-12238	C - 5	90501-104F9	B - 13		F - 6	93306-30525	C - 14	95026-06030	E - 11	95817-06020	C - 7
90464-13073	F - 13	90501-12743	E - 13		F - 12	93306-37207	E - 7	95027-06010	D - 5	95817-06025	C - 8
90464-13077	F - 10	90501-237L0	C - 12	92907-08200	E - 7	93310-365B8	C - 13	95027-06012	E - 10	95817-06030	C - 7
90464-15192	E - 2	90506-18224	E - 13	92907-08600	C - 12	93315-11206	C - 12	95027-06014	B - 11	95817-06045	C - 8
	F - 5	90506-20192	E - 15	92990-05600	B - 10	93317-11020	C - 12		F - 10	95817-06050	C - 11
	F - 13	90506-26225	E - 13	92990-06600	C - 6	93317-21236	C - 9	95027-06016	B - 9	95817-06055	C - 7
90464-15195	F - 13	90508-167A3	C - 12	93101-12004	D - 3	93320-32403	D - 10		B - 14	95817-06070	C - 7
90464-20191	F - 5	90508-297A4	D - 2	93102-12224	C - 12	93340-21505	C - 12	95027-06020	B - 11		C - 8
	F - 13	90508-32682	D - 3	93102-25044	E - 7	93399-99931	D - 12		B - 12	95817-06090	C - 10
90464-25217	F - 5	90560-07007	D - 8	93102-28022	E - 5	93399-99932	D - 12		D - 5	95817-08035	F - 3
	F - 13	90560-17233	E - 5	93102-35459	C - 14	93440-10109	B - 2		F - 11	95817-08065	C - 7
90465-08122	C - 9	91314-06020	B - 13	93105-42024	E - 7	93440-25084	C - 14	95027-06025	B - 11	95817-08070	C - 7
90465-08127	C - 9		B - 14	93109-12075	C - 9	93440-31172	C - 14		B - 12	95817-08075	C - 8
90465-08341	C - 8	91314-06025	B - 8	93109-18020	D - 11	93440-45144	C - 15		C - 9	95817-08080	F - 3
90465-08380	F - 6		B - 14	93210-07135	B - 14	93450-22027	B - 4	95027-06035	B - 13	95827-06010	E - 15
90465-14310	F - 8	91314-08016	C - 7	93210-10096	B - 13	93501-04011	E - 13		C - 10	95827-06012	C - 15
90465-15384	C - 9	91314-08030	D - 12		B - 14	93505-08030	B - 13	95027-08025	C - 6	95827-06020	D - 3

NUMERICAL INDEX

PARTNO.	GRID NO.	PARTNO.	GRID NO.	PARTNO.	GRID NO.	PARTNO.	GRID NO.	PARTNO.	GRID NO.	PARTNO.	GRID NO.
95827-08040	D - 6	99009-12400	B - 9								
95827-10030	E - 9	99009-19400	D - 3								
97007-05012	B - 10	99226-00140	D - 15								
97007-06025	C - 2	99227-00140	D - 15								
	D - 10	99246-00080	D - 6								
97007-08030	D - 15	99247-00080	D - 6								
97706-40620	F - 7		F - 3								
	F - 10	99510-08016	B - 2								
97707-40010	F - 3	99530-08012	B - 12								
97707-40018	F - 8		C - 8								
97707-40620	F - 7		C - 9								
97707-50012	D - 6		C - 10								
	F - 4	99530-08016	B - 13								
97707-50125	B - 15		C - 8								
98506-04014	E - 11	99530-10114	C - 7								
98507-03008	D - 15		C - 10								
98507-04006	B - 2	99530-14016	B - 3								
98507-04008	B - 11		C - 7								
	C - 3										
98507-04014	C - 3										
98507-04018	C - 3										
98507-05008	B - 10										
98507-05010	B - 10										
	C - 3										
	C - 9										
	E - 2										
98507-05012	C - 4										
98507-05016	B - 15										
98507-05022	F - 11										
98507-05025	F - 11										
98507-05035	E - 10										
98507-05045	F - 11										
98507-06008	F - 12										
	F - 13										
98507-06010	B - 12										
98507-06016	F - 12										
	F - 13										
98507-06035	B - 12										
	F - 6										
98507-06045	B - 12										
98706-04012	E - 11										
98707-03020	F - 11										
98907-05010	D - 6										
98907-06012	F - 12										
99001-07600	C - 12										
99001-10600	D - 3										
99009-10400	C - 12										
99009-11400	B - 12										

CONTENTS

ENGINE

CYLINDER HEAD	B2
CYLINDER	B3
CRANKSHAFT. PISTON	B4
VALVE	B6
CAMSHAFT. CHAIN	B8
WATER PUMP	B9
RADIATOR. HOSE	B10
OIL PUMP	B12
INTAKE	B15
CARBURETOR	C3
EXHAUST	C6
CRANKCASE	C7
CRANKCASE COVER 1	C9
STARTER CLUTCH	C11
CLUTCH	C12
TRANSMISSION	C14
SHIFT CAM. FORK	D2
SHIFT SHAFT	D3

CHASSIS

FRAME	D4
FENDER	D5
SIDE COVER	D8
REAR ARM	D10
REAR SUSPENSION	D11
STEERING	D12
FRONT FORK	D13
FUEL TANK	D15
SEAT	E4
FRONT WHEEL	E5

FRONT BRAKE CALIPER	E6
REAR WHEEL	E7
REAR BRAKE CALIPER	E9
STEERING HANDLE. CABLE	E10
FRONT MASTER CYLINDER	E11
STAND. FOOTREST	E13
REAR MASTER CYLINDER	E15
COWLING 1	F3
GENERATOR	F6
FLASHER LIGHT	F7
METER	F8
HEADLIGHT	F9
TAILLIGHT	F10
HANDLE SWITCH. LEVER	F11
ELECTRICAL 1	F12
ELECTRICAL 2	F13

INDEX

NUMERICAL INDEX	M1
-----------------------	----